

M.T.M. ELECTRIC TRAINS

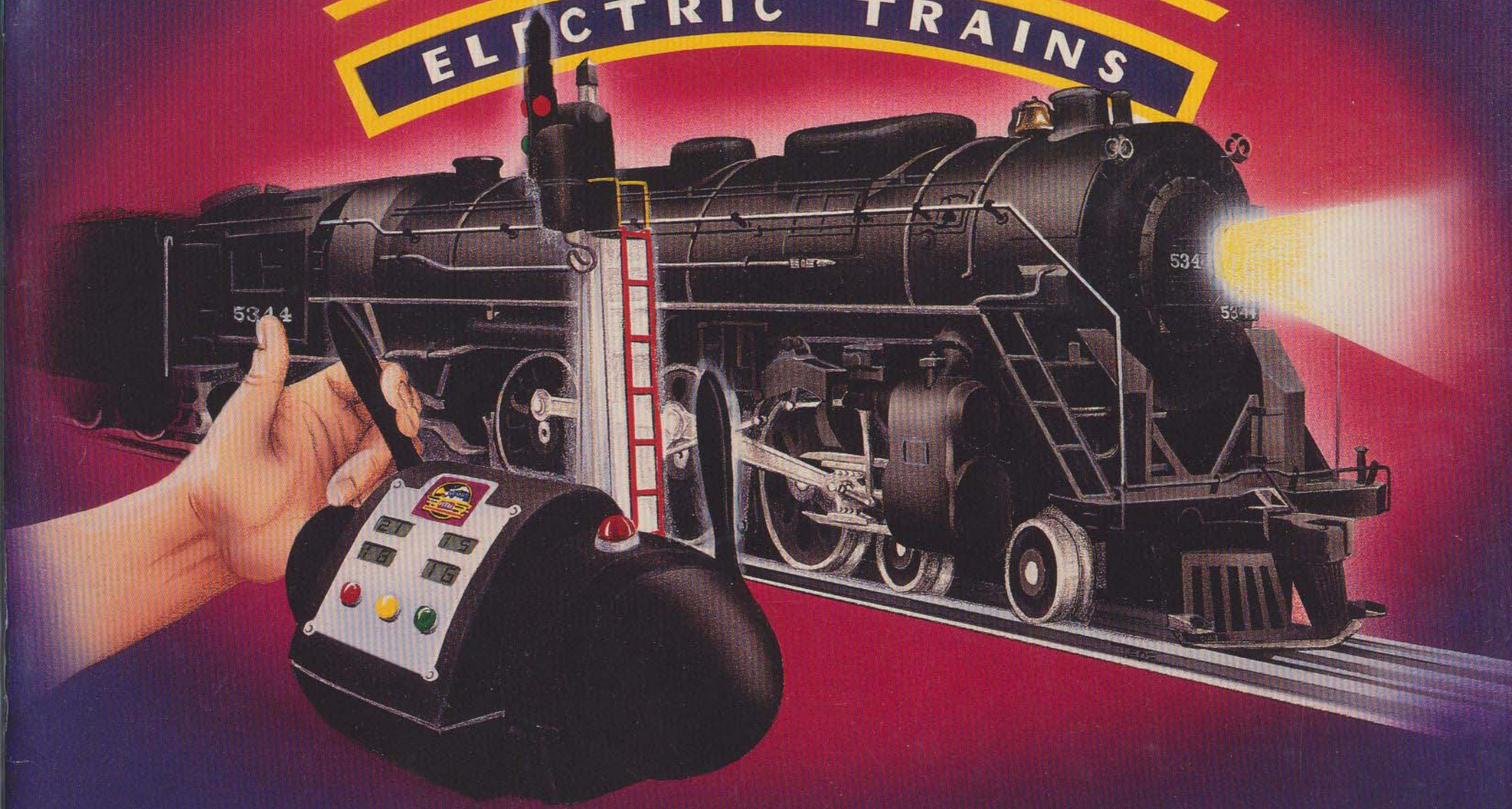

Fall/Winter 1996

THANKS FROM MTH

AN OPEN LETTER FROM MIKE WOLF

As I sit at my desk reviewing the pages in our Fall 1996 Line, my mind starts to wander back to the past. I'm sure it's the sight of the #94 High Tension Towers and the 200 Series Cars on pages 6 and 8 that bring back many fond memories.

My thoughts drift back to 1973 and my first real job! It was assembling standard gauge couplers like the ones used on the 200 Series Cars. Well, it didn't take me long to realize that I liked this business; for only seven years later, I started my own company with its headquarters located in my bedroom of my parents house. By 1983 I started manufacturing Standard Gauge trains. This forced my business to seek larger quarters, but I quickly found the perfect location: my parent's basement. My, were they ever understanding.

In 1987, my business really began to grow when I started to



produce the entire LIONEL CLASSIC™ LINE for Lionel Trains, Inc. The operation, of course, had long moved out of my parent's basement. Two years later found us manufacturing Die-Cast Scale Steam Engines for Lionel starting with the Reading T-1 and the NYC L-3 Mohawk. Over the next few years we developed and produced other locomotives and cars for Lionel including the Western Maryland Shay, Pennsylvania Steam Turbine & N8 Caboose, Alco PA's, MU Cars, Southern & Frisco Mikado's, Pennsy Silver GG-1s, the Lift Bridge, and the Semi-Scale Freight Cars.

| | |
|--------------------------------|----|
| Thanks From MTH | 2 |
| MTH Tinplate Traditions | 4 |
| 200 Series Freight Cars | 6 |
| 800 Series 'O' Freight Set | 7 |
| Standard Gauge Tower Sets | 8 |
| Tinplate Accessories | 9 |
| Premier Line | 10 |
| GP-20 Diesel | 12 |
| O Scale Rolling Stock | 14 |
| 70' Scale Madison Sets | 16 |
| 60' Aluminum Car Sets | 18 |
| Z-2000™ Transformer | 22 |
| NYC J-1e Hudson | 24 |
| RailKing Line | 28 |
| ProtoSound™ Electronics | 30 |
| PCC Electric Street Car | 31 |
| NYC Dreyfuss Hudson | 32 |
| SD-60 Diesel | 34 |
| Scale 0-8-0 Switcher | 36 |
| O-27 Passenger Cars | 38 |
| Semi-Scale Freight Cars | 40 |
| RailKing Sets | 44 |
| Layout Accessories | 46 |
| RailTown™ Buildings | 47 |

After almost 5 years of working behind the scenes for Lionel, I began producing my own line of "O" Gauge trains. Starting with the attractive DASH-8 Diesel and quickly moving to the first articulated O Gauge die-cast steam engine: the Union Pacific Challenger. MTH Electric Trains proved to be very popular.



Since that time, we have introduced more new tooled locomotives in the past 3 years than any other "O" Gauge manufacturer today. We were the first "O" Gauge manufacturer to introduce factory installed microprocessor based "Digital Sound" locomotives. With the help of two very talented electronic engineers at QS Industries, we were the first manufacturer to introduce exciting, state-of-the-art features like "CAB CHATTER", "ENGINE START-UP and SHUT DOWN", "STEAM BLOW-DOWN" and "STEAM INJECTOR" sounds. Our revolutionary ProtoSounds Proto-Effects™ have given O Gauge customers "PASSENGER STATION ANNOUNCEMENTS", "FREIGHT YARD SOUND EFFECTS", "SQUEAKING BRAKES", and many other sound and control features, all of which can be controlled from any compatible AC Transformer.



With the introduction of our new "RAILKING™" Line in 1995, we set a new standard for O-27 and "O" Gauge Trains. While other manufacturers are playing "catch-up", we guarantee that our RailKing line will possess the highest quality products in their price range. And, you won't pay one dime more for the name on our box!

As you page through this new catalog you will find that there are even more newly tooled products from which to choose. The long awaited Z2000 Transformer, a scale 0-8-0 Switcher, and the most detailed Scale NYC Die-Cast Hudson ever made are just some of the many items we are excited to present.



Although I have been in this business for 23 years I still feel like "THE NEW KID ON THE BLOCK" and it's really fun! I want to thank all the customers who have supported me over the years because without you I wouldn't be sitting here reviewing such an exciting catalog. But I still need your help. Please show this catalog and any of our products to some friends so they can compare what we have to offer to any other manufacturer making trains today. If this is the first time you have seen one of our catalogs I would encourage you to visit one of our Dealers. Ask them to *demonstrate* our products alongside one of our competitors. I think you'll be amazed at the differences in quality and value!

Happy Railroading

Mike Wolf
President, MTH Electric Trains



TINPLATE TRADITIONS



Our beginnings, like so many of our model railroading fans, literally started in the basement - because it was in the basement where we first started assembling the parts that would later become the first MTH Tinplate Traditions. And, as these hand assembled and beautifully painted parts came together, it likely marked the start of a new model railroading fan's very own tinplate tradition.

Whether it was a 400E, a 381 or a 263, railroading's past was not to be forgotten as these first MTH tinplate products rolled out of our basement and into the

collections and hearts of many. We at MTH are keenly aware of the importance that these early toy trains have on today's hobby as well as on our own success. For without tinplate, the toy train hobby would surely lack some of its attractive appeal.

As we unveil our latest Tinplate Traditions over the next few pages, we hope that you will take the time to marvel not only at our own recreations, but at the impact those early toy trains had on today's manufacturers. As always, we welcome any suggestions you might have for future tinplate productions.

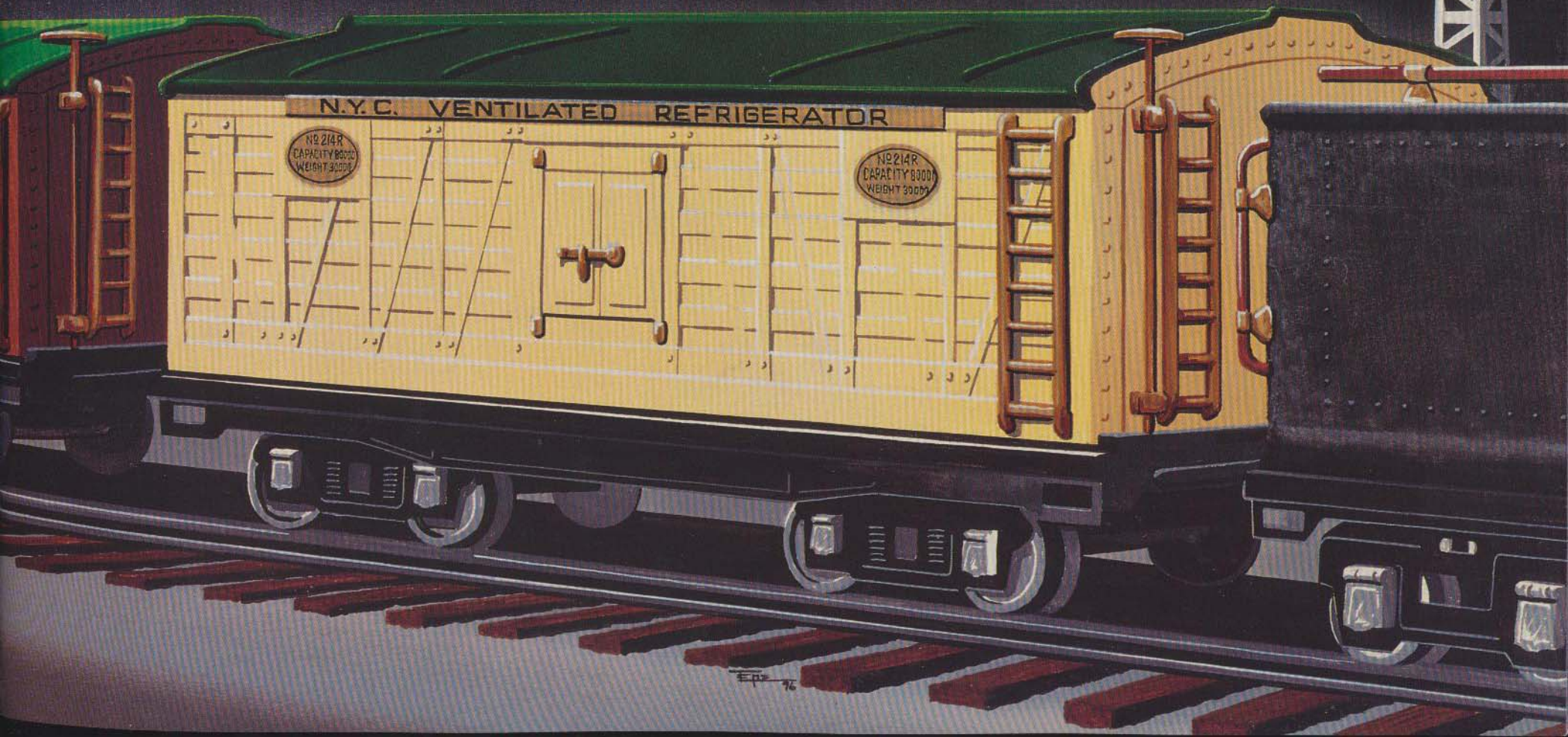

200 SERIES FREIGHT CARS

MTH is bringing back the tinplate tradition in exciting fashion with the release of three beautifully created 200 Series Freight cars. The 213 Stock Car, 214 Box Car and 214R Reefer will be the centerpiece of your standard gauge collection thanks to their quality MTH construction and bright attractive baked enamel finish.

Like all MTH tinplate traditions, the 200 Series cars are entirely constructed from stamped metal compo-

nents. Each car contains black oxide finished trucks, nickel truck journal boxes and sprung latch couplers for that authentic feel of yesteryear. Equally at home behind the majestic MTH 408E or any large standard gauge locomotive, these stunningly attractive freight cars add color and variety to any standard gauge layout or Christmas Garden. Start collecting the first of a continuing series.



CHOOSE FROM TWO
DIFFERENT PAINT SCHEMES

214 BOX CARS



213 STOCK CARS



214R REEFER CARS



800 SERIES O GAUGE FREIGHT SET

MTH is proud to bring back the bright colors and finplate styling of yesteryear's all-metal trains for the O and O-27 markets with our production of the classic 800 Series freight cars. Each car in our four-car set features MTH quality construction, stamped metal components and a flawless, baked enamel finish.

All the cars in the 800 Series set feature authentic box couplers that can be coupled behind any MTH steam

engine using the MTH knuckle adapt-a-coupler included in your set. This handy adapter allows you to couple up a classic tinplate set behind today's powerful, smooth running locomotives like our RailKing Hudson or Berkshire steam engines. It's a great way to experience the color, fun and feel of model railroading's glory days.



812 GONDOLA CAR



No. 1042
4-CAR TINPLATE
O-GAUGE FREIGHT SET

816 HOPPER CAR

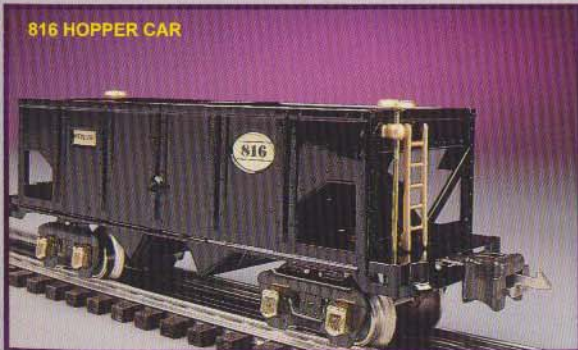

814 BOX CAR



817 CABOOSE



TINPLATE ACCESSORIES

MTH is proud to bring back two of the most popular standard gauge tinplate accessories ever built: the No. 94 High-Tension and No. 92 Floodlight Towers! Both are recreated to the exact dimensions and colors as their original ancestors and are packaged in sets of three. The Floodlight Tower features two working floodlights that can be powered from any AC transformer. The improved thumbscrew wiring posts make powering up these beautiful towers quick and easy!

#92 FLOODLIGHT TOWER

Each Floodlight Tower Measures Almost 21 Inches Tall

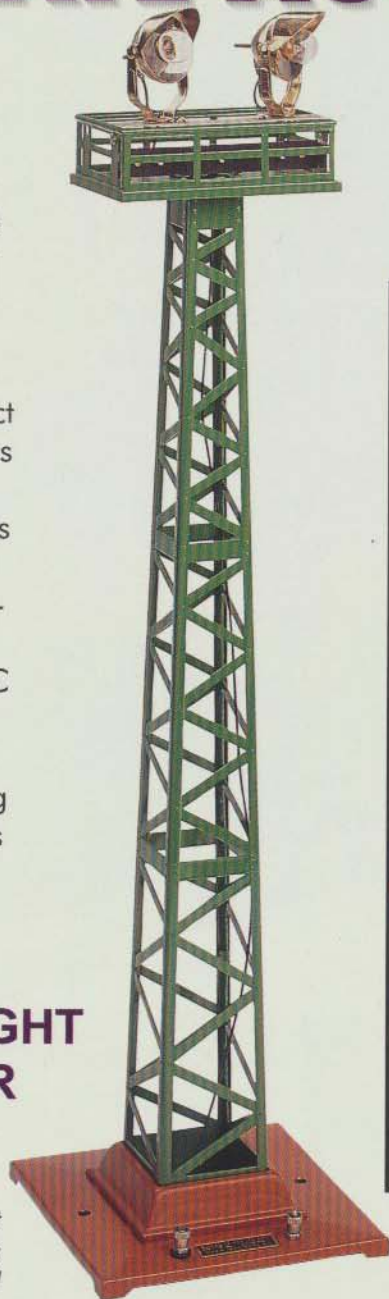

No. 92 Floodlight Tower 3 Pc. Set - Item No. 1044

#94 HIGH-TENSION TOWER

PACKAGED IN 3 TOWER SETS

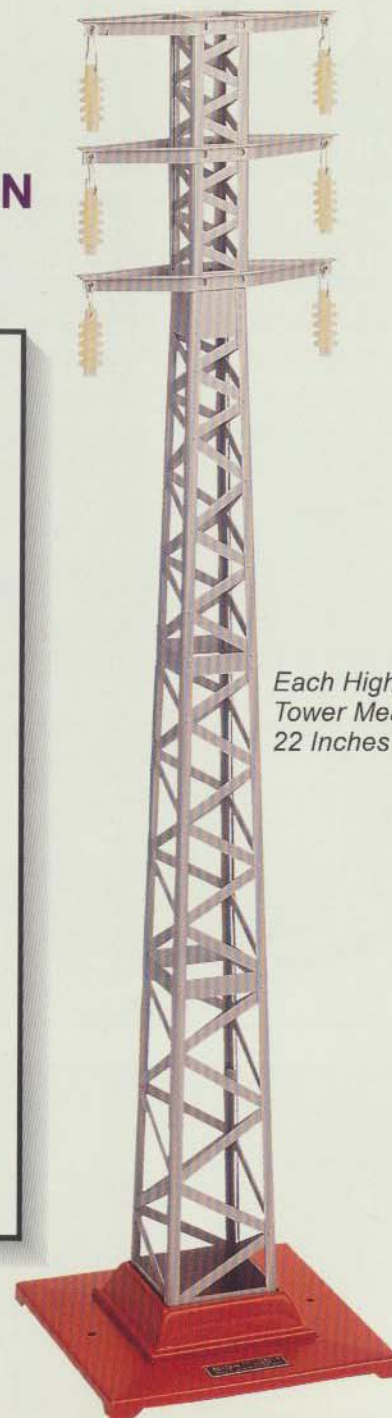
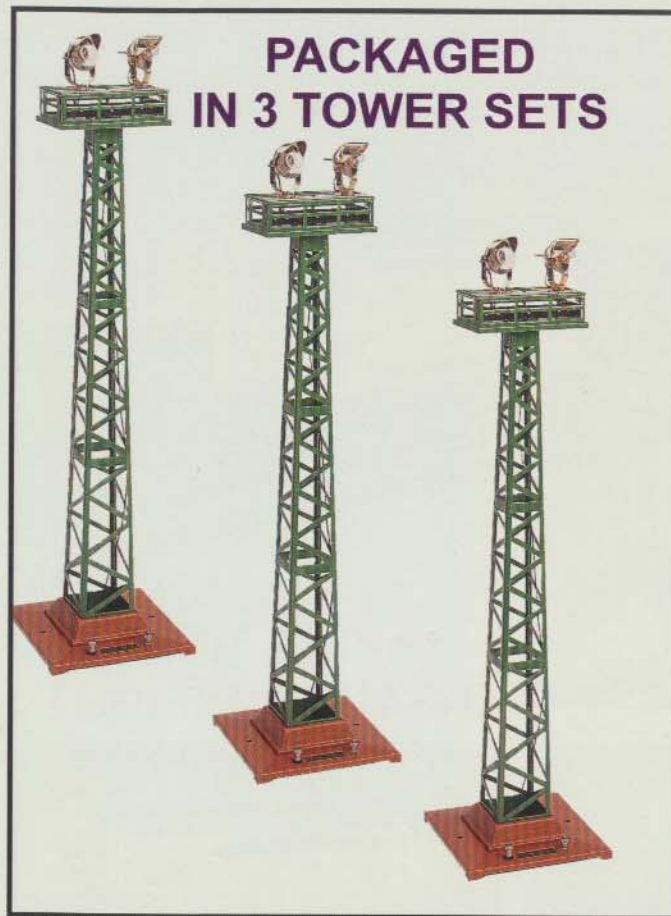

Each High-Tension Tower Measures 22 Inches Tall

No. 94 High-Tension Tower 3 pc. Set - Item No. 1043

#153 BLOCK SIGNAL & T.A.D.



#153 Signal
Measures
9 Inches Tall

Available In:
Green & Silver - Item No. 1034

#69N OPERATING WARNING BELL & T.A.D.



#69 Warning Bell
Measures
8^{3/4} Inches Tall

Available In:
Red & Silver - Item No. 1036

Standard Gauge Lighted Track Lock-On



Available In:
Std. Gauge - Item No. 1021

#151 OPERATING SEMAPHORE & T.A.D.

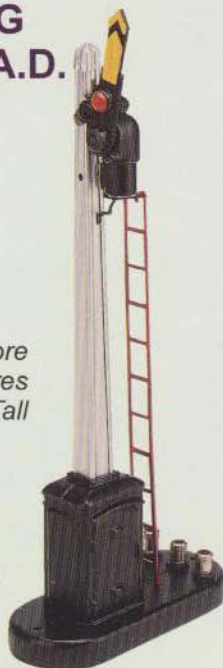

#151 Semaphore
Measures
9 Inches Tall

Available In:
Red & Silver - Item No. 1035

#6200 O GAUGE TRACK ACTIVATION DEVICE (T.A.D.)



Available In:
O Gauge - Item No. 1037

MTH Standard Gauge Track

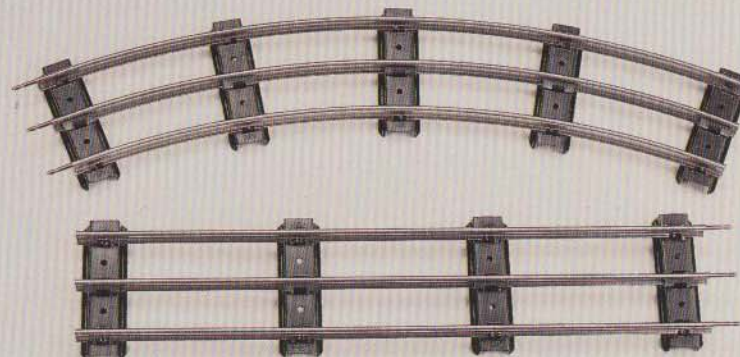

Available In
Regular Straight Section - Item No. 1038, Regular Curve Section - Item No. 1039,
Extra Tie Straight Section - No. 1040, Wide Radius Curved Section - No. 1041

**MTI
PREMIER**

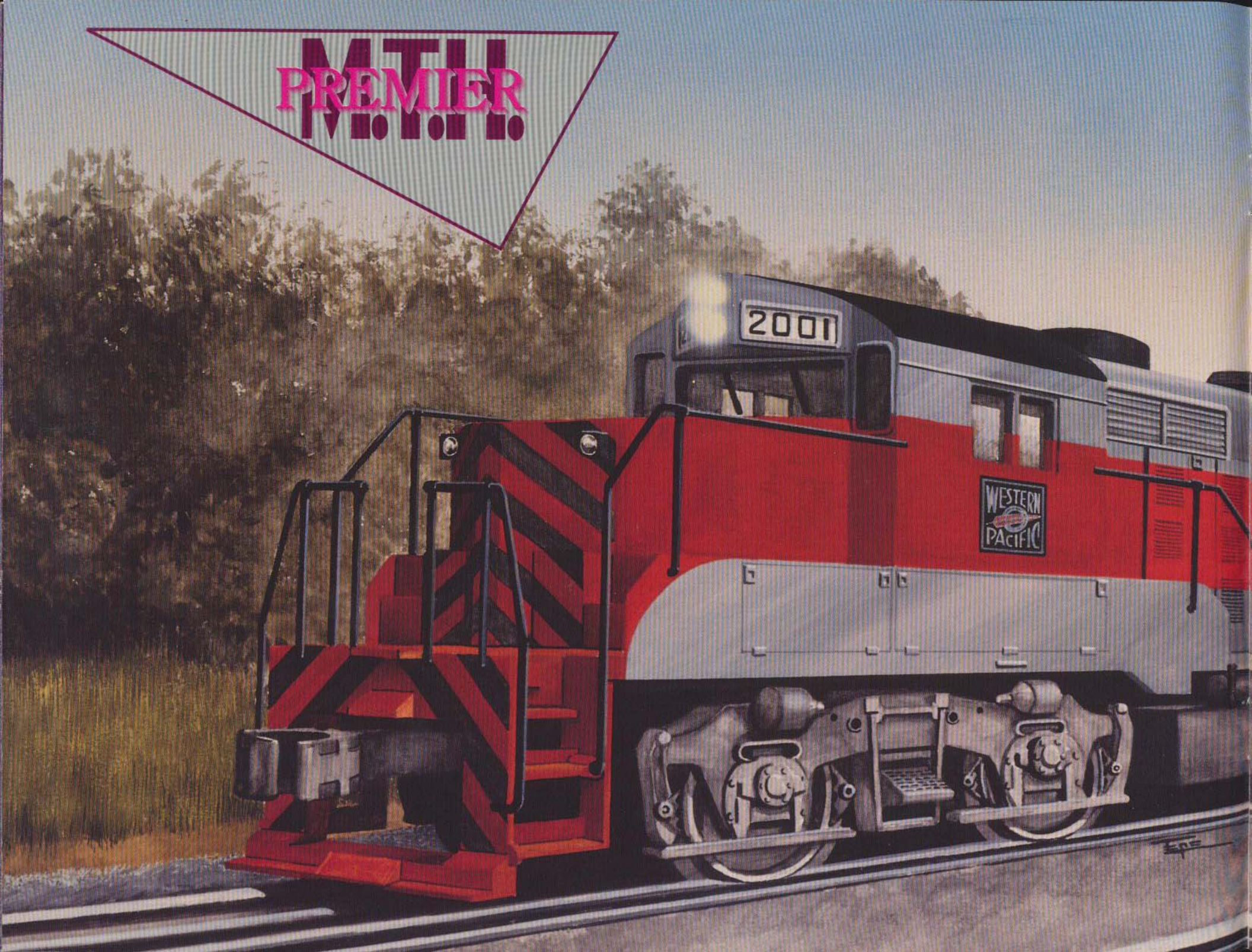

Over the next several pages you will find exciting new offerings from the MTH Premier Line. Each of these products contains exciting features, like lighted cab interiors, not found elsewhere. You will also find Premier engines equipped with ProtoSound digital sound and train control, flywheel equipped motors for smooth starts and stops, engineer figures, constant voltage headlights and paint schemes guaranteed to match their MTH siblings. Best of all, each MTH Premier item is so affordably priced that you won't be afraid to operate them.



GP-20 DIESEL LOCOMOTIVES

In order to stay competitive and meet increasing railroad demands for more horsepower, the Electro-Motive Division of General Motors introduced the 2000-horsepower GP-20 diesel in 1959. Despite the fact that only 244 units were produced, this symbol of power and progress was instrumental in ushering in the era of turbocharged diesels.

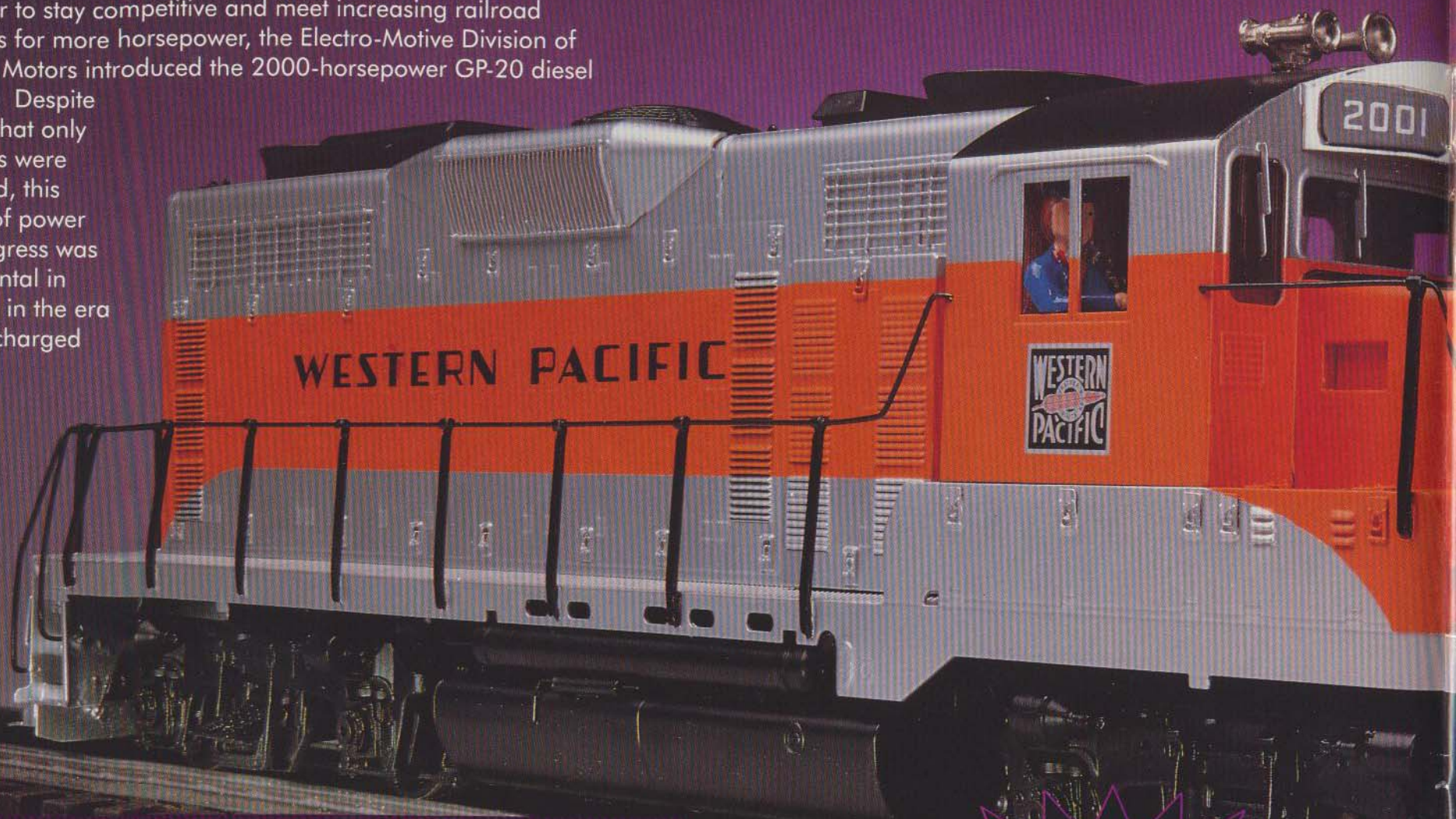

GP-20 LOCOMOTIVE

- Directionally Controlled Headlights
- Die-Cast Trucksides, Pilots and Fuel Tank
- Remote Controlled Proto-Couplers™
- Colorful Paint Schemes
- 2 or 3-Rail Versions
- Operates On O-31 Track
- Metal Handrails & Horn
- Compatible With Most AC Transformers

- ProtoSound™ Digital Sound Control With Squeaking Brakes & Freight Yard Proto-Effects™ Sounds
- 2 Precision Flywheel Equipped Motors
- Lighted Cab Interior
- Cab Engineer Figure
- Measures Approximately 15^{1/4} x 2^{1/2} x 3^{3/4}.

Equipped With

PROTO-SOUND
™

DESIGNED BY **GSN**

See Page 30 For Details

MTH Electric Trains brings to life the power of the history-making GP-20 in our 1/4 scale Premier Line diesel. With powerful dual flywheel-equipped motors and heavy die-cast metal trucks and couplers, the GP-20 is capable of performing any task on your pike. Finally, the GP-20 adds a new dimension to your layout operations with our exclusive Freight Yard Sounds, just one of the many standard features you'll find in the state-of-the-art ProtoSound digital sound system.

Available in four paint schemes, including the latest in our Builder Series, you're sure to find a GP-20 in your favorite roadname.

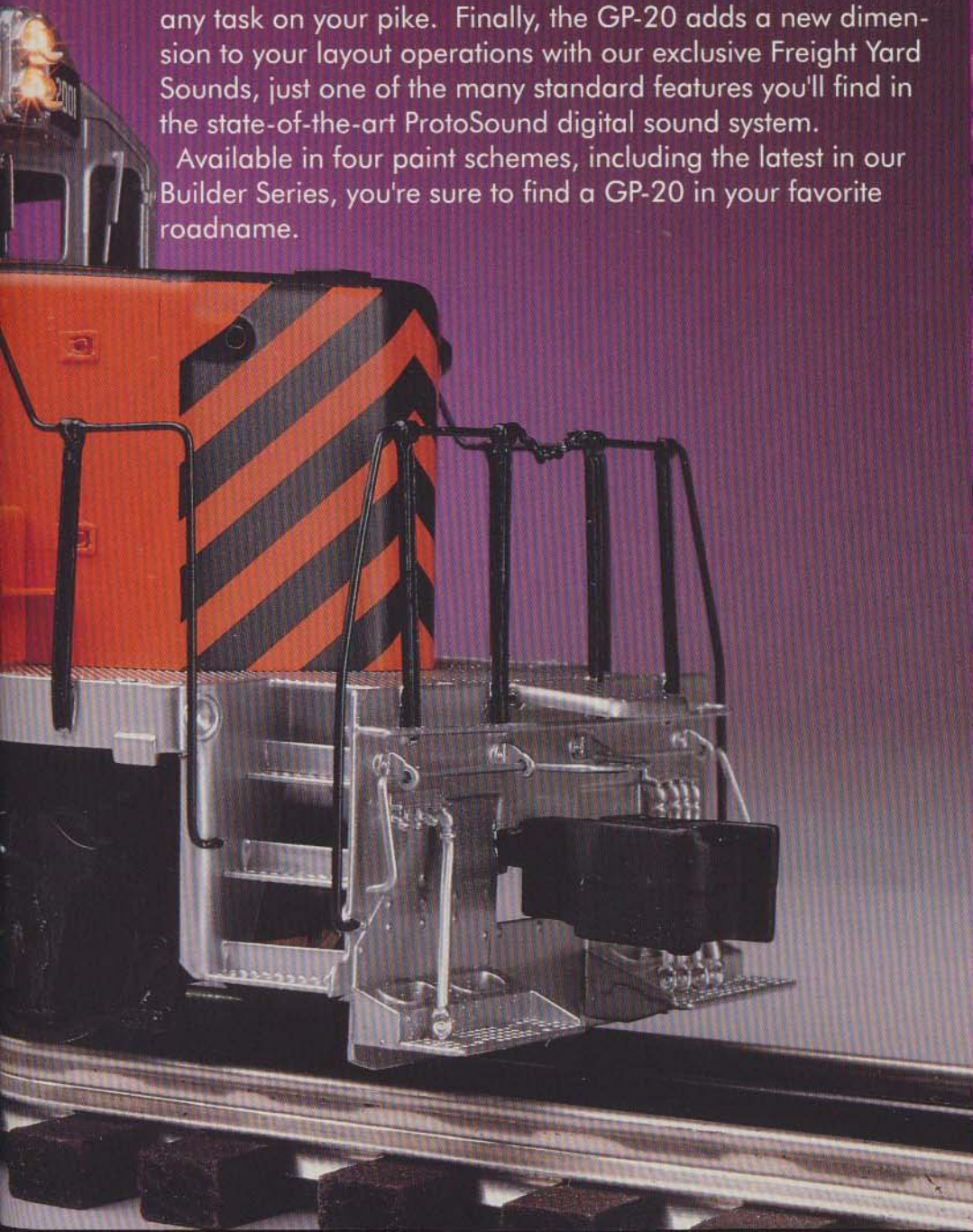

ALSO AVAILABLE IN

EMD GP-20 Diesel - Item No. 2142



BUILDERS SERIES - No. 4

A.C.L. GP-20 Diesel - Item No. 2139



Burlington Northern GP-20 Diesel - Item No. 2140



O SCALE ROLLING STOCK



Give your MTH Premier Line engines a consist of freight cars they would be proud to pull: the exciting MTH O Scale Freights. These colorfully decorated scale proportioned freight cars are an exciting new addition to our line including our never before offered All-Purpose Husky- Stack car. These full length scale cars are 1/4 scale recreations of some of the latest container based transportation cars running on today's rails. Our cars contain two 40' removeable containers with the total car length running just about 18 inches.

ALL NEW HUSKY-STACK SCALE LENGTH CARS



APL Husky-Stack - Item No. 9500



MTH SCALE FREIGHT CARS
FEATURE AUTHENTIC DETAIL

Each car is constructed from ABS plastic bodies and mounted atop die-cast, sprung trucks with operating metal couplers. The intricately detailed bodies and smooth rolling trucks are bound to make these MTH Scale Freights some of your roster's favorites. Choose from two

Reefers, two new Uni-Body tank cars or 40' Boxcars. Two new Extended-Vision cabooses also make their debut along with two schemes in our all new All-Purpose Husky-Stack cars. We're sure you'll find any or all of these exciting O Scale cars to be a perfect fit on your railroad!

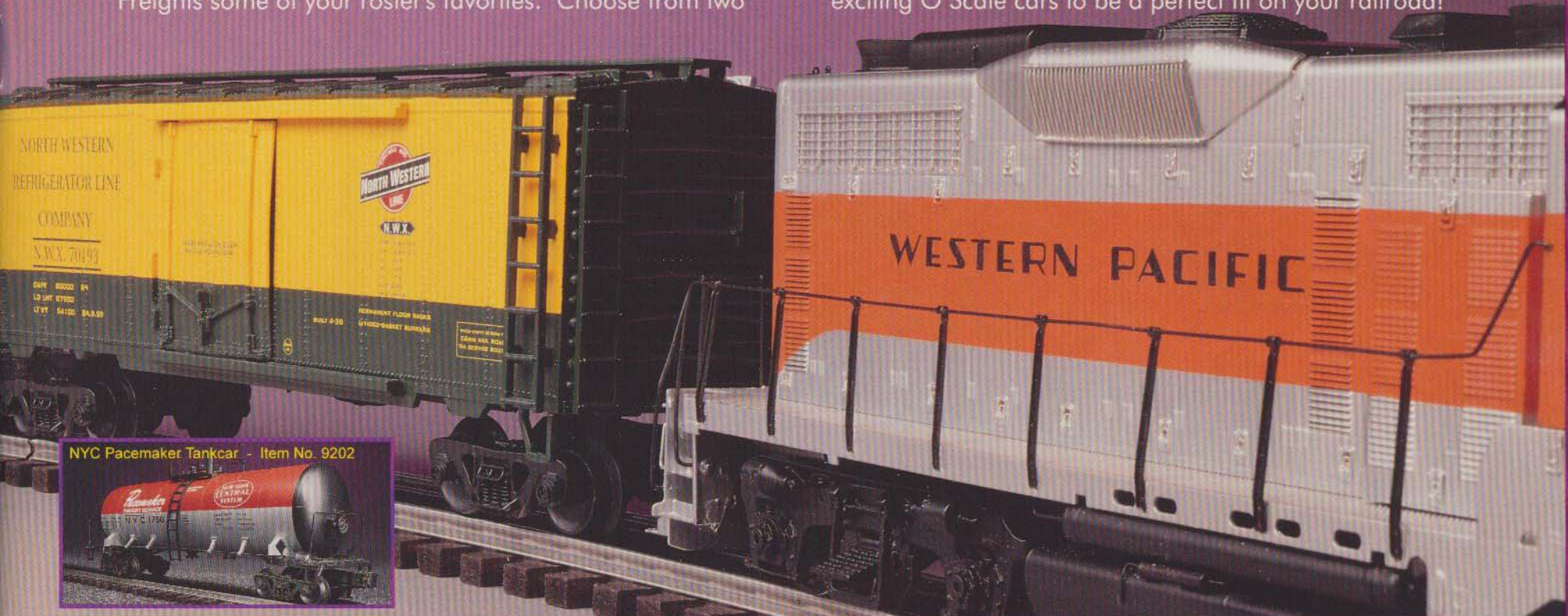

NYC Pacemaker Tankcar - Item No. 9202



Burl. Northern Husky-Stack - Item No. 9501



ATSF Super Chief Boxcar - Item No. 9303



National Car Company Reefer - Item No. 9402



Chesapeake & Ohio Caboose - Item No. 9102



Chicago Northwestern Reefer - Item No. 9403



Norfolk & Western Caboose - Item No. 9103



Chicago Northwestern Tankcar - Item No. 9203



Pennsylvania Boxcar - Item No. 9302



70' SCALE MADISON SETS

To a railfan, there is nothing quite as stunning as a colorfully decorated passenger train. The MTH scale length heavyweight Madison style cars are no exception.

The colorful, five-car 1/4 scale sets are painted specifically to match some of your favorite MTH steam or diesel

engines. Each car is ABS molded in intricate detail and sits atop die-cast six wheel smooth rolling trucks.

Each five-car set is carefully painted to match previous MTH paint schemes. Our 1996 run features three great roadnames and makes perfect additions for the MTH



Pennsylvania K-4 or NYC J-1e Hudson engines. Each set contains one baggage car with sliding baggage doors; three coach cars, each with interior illumination and sprung loaded doors; and a beautifully detailed observation car - complete with observation deck, operating

marker lights and sprung doors. Each car also contains metal handrails, die-cast operating couplers and silhouette window strips.



70' SCALE MADISON SETS

- Die-Cast 6 Wheel Trucks
- **Operating Die-Cast Couplers**
- 3 Colorful Paint Schemes
- 2 3rd Rail Pickups Per Car
- Operates On O-42 Track
- Metal Decorative Handrails
- 5-Car Set Contains 1 Baggage, 3 Coaches & 1 Observation Car
- **Sprung Loaded Operating Doors On Coach & Observation Cars**
- Sliding Baggage Doors On Baggage Car
- Coach & Observation Car Feature 4 Interior Bulbs
- Operating Observation Deck Marker Lights
- Each Car Measures 18' Long

Pullman 5-Car Madison Set
Item No. 4020



Pennsylvania Tuscan/Black 5-Car Set
Item No. 4018



New York Central 5-Car Set
Item No. 4019



60' ALUMINUM CAR SETS



It's the return of our popular aluminum car sets, back again in affordable 4-car sets!

These traditional length cars are a perfect fit to run behind any semi-scale engine on O-31 curves. Each car

measures approximately 15 inches in length and sports the distinctive styling that has made streamlined cars the choice of many railfans over the years.



Available in three popular roadnames, these cars are painted to match popular motive power from MTH and RailKing, including the Santa Fe Streamlined Northern, Union Pacific Challenger and Pennsylvania K-4 and GG-1 legends. Additional 2-car sleeper and diner sets can be found on pages 20 and 21 allowing you to make an even longer consist!

60' 4-CAR ALUMINUM SETS

- Die-Cast 4 Wheel Trucks
- Operating Die-Cast Couplers**
- 3 Colorful Paint Schemes
- Two 3rd Rail Pickups Per Car
- Operates On O-31 Track
- All Aluminum Body Extrusions
- 4-Car Set Contains 1 Baggage, 1 Coach, 1 Vista Dome & 1 Observation Car
- Sliding Baggage Doors On Baggage Car
- Coach, Vista Dome & Observation Car Feature 2 Interior Bulbs
- Glowing Observation Roof Marker Lights
- Die-Cast Trucks Feature Fast-Angle Wheels, Needle Point Axles and Oil-lite Bearings
- Each Car Measures 15" Long

Pennsylvania 4-Car Aluminum Set - Item No. 6017



Santa Fe Blue Goose 4-Car Set - Item No. 6018



Union Pacific 4-Car Aluminum Set - Item No. 6019



60' ALUMINUM SLEEPER/DINER SETS

MTH Premier and RailKing locomotives possess incredible pulling strength. These engines are often more than capable of pulling the typical four or five-car passenger sets sold today.

By adding an MTH 60' Aluminum Sleeper/Diner Set to your older 60' Aluminum Car Sets, you can put your engines to work doing what they were designed for - pulling long passenger consists. These attractive two-car sets are painted to



Union Pacific 60' Sleeper/Diner Set
Item No. 6115



Union Pacific 60' Sleeper/Diner Set
Item No. 6119



match previous production runs of four and five-car sets. They are the perfect way to give your layout that long, handsome consist. Each car features the same quality die-cast trucks found on our aluminum sets. In addition, the trucks feature operating metal couplers and fast-angle wheels for smooth rolling performance.

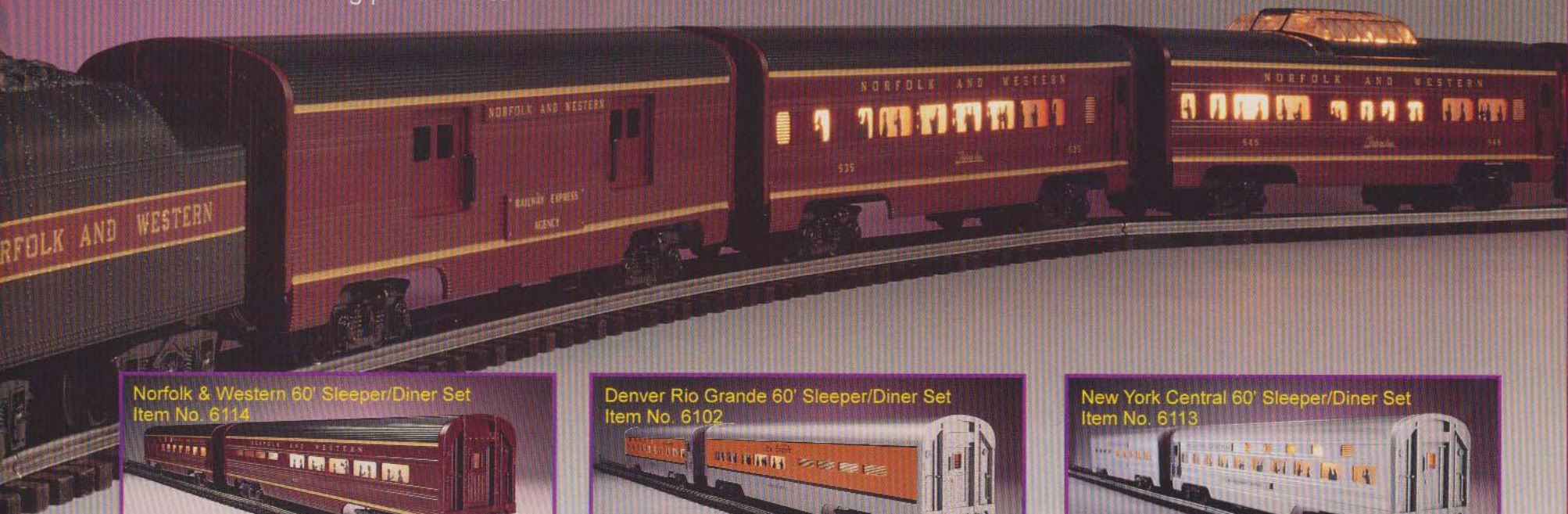

Norfolk & Western 60' Sleeper/Diner Set
Item No. 6114



Denver Rio Grande 60' Sleeper/Diner Set
Item No. 6102



New York Central 60' Sleeper/Diner Set
Item No. 6113



Santa Fe 60' Sleeper/Diner Set
Item No. 6116



Santa Fe Blue Goose 60' Sleeper/Diner Set
Item No. 6118



Baltimore & Ohio 60' Sleeper/Diner Set
Item No. 6112



Florida East Coast 60' Sleeper/Diner Set
Item No. 6105



B&O Cincinnati 60' Sleeper/Diner Set
Item No. 6108

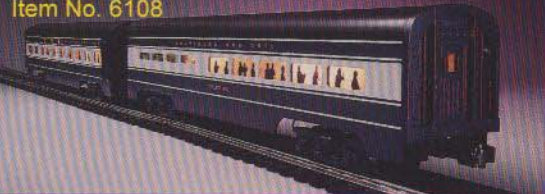

California Zephyr 60' Sleeper/Diner Set
Item No. 6120



Z-2000 TRANSFORMER

At long last, MTH answers one of the most basic needs of the O Gauge market: a modern powerful transformer that is fully compatible with any AC powered locomotive built from 1900 to today and beyond.

The Z-2000 may sound like a futuristic device, but this modern, state-of-the-art powerful transformer retains the style and feel of yesteryear's powerhouses. Better design and superior engineering mean the Z-2000 is the most compatible 3-rail AC transformer available today and can operate virtually any O Gauge train. More importantly, you need not worry about the hazards of operating your layout with an old transformer.

Capable of producing a whopping 190 watts from one circuit, the Z-2000 is more than up to the task of even the most demanding operator. It features two variable track



outputs plus two fixed voltage outputs. Adorned with modern conveniences, like digital displays for amperage and voltage output gives the operator up-to-the-second analysis of his railroad's operating track power. Additional features include power on and overload warning lamps, smooth and easy feeling throttle handles

and a variety of push button controls for activating every ProtoSound feature as well as the basic features of any O Gauge locomotive.

With the Z-2000, you can control an engine's direction, whistle and horn, as well as the bell without the need for any additional devices. Hook up is quick and easy thanks to the quick connect wire terminals.

ProtoSound operation was never easier than with the Z-2000. No more fumbling with your voltage settings to access a ProtoSound feature. Now all of your programming can be accessed with the simple push of the program button located on the Z-2000's face. You simply

Z-2000 TRANSFORMER

- Traditional Styling
- High Impact Casing
- 190 Watt RMS Output
- Resettable Circuit Breaker
- Digital Voltage Display
- Digital Amperage Display
- Two Variable Track Output Channels
- 14 Volt Fixed Output Channel
- 10 Volt Fixed Output Channel
- Easy Access On/Off Switch
- Stamped Metal Mounting Base
- Power On And Overload Warning Lamps
- Left And Right Channel Controls
- Whistle/Horn Buttons
- Bell Buttons
- Direction Buttons
- ProtoSound Programming Buttons

access any ProtoSound RESET feature, like remote volume adjustment by pressing the Z-2000 program button. Your ProtoSound equipped engine plays back simple bell tones to indicate which feature you enter with each push of the program button. It's as simple as counting!

The MTH Z-2000, you'll find it's today's best transformer for today's best trains.

State-Of-The-Art Design

Digital Readout Display

Classic Styling

Affordably Priced

Z-2000 TRANSFORMER



Operates All O Gauge Trains

Push Button Controls

Z-2000 190 Watt Transformer
Item No. Z2000

NYC J-1e HUDSON LOCOMOTIVE



NEW YORK CENTRAL J-1e

- Constant Voltage Headlight
 - Operating Marker Lights
 - Die-Cast Leading & Trailing Locomotive Trucks
 - Precision Pittman Motor With Flywheel Drive Train
 - **Remote Controlled Metal Proto-Coupler™**
 - Firebox Glow
 - 2 or 3-Rail Versions
 - Operates On O-31 Track
 - Metal Handrails & Decorative Whistle
- Compatible With Most AC Transformers
 - **ProtoSound™ Digital Sound Control With Squeaking Brakes And Passenger Station Proto-Effects™**
 - Die-Cast Boiler & Tender Bodies
 - Lighted Cab Interior
 - Cab Engineer Figure
 - The Most Detailed O Gauge Hudson Ever Produced
 - Measures Approximately 25" x 2 1/2" x 3 5/8"

Equipped With

PROTO - SOUND™

DESIGNED BY **OSTN**

See Page 30 For Details

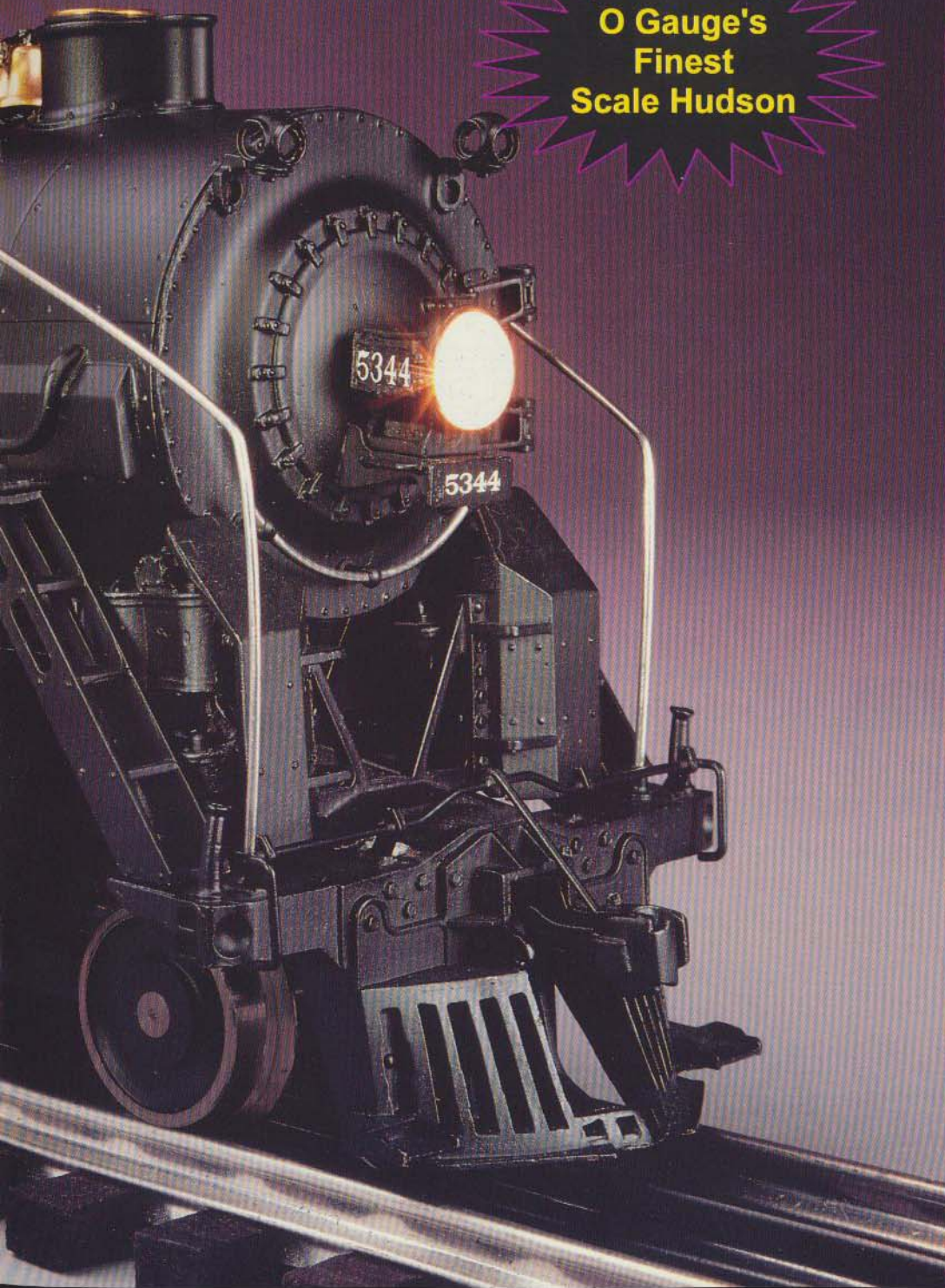

**O Gauge's
Finest
Scale Hudson**

From its first entry into service, the J1 4-6-4 Hudson established an imposing standard for heavy haulage at high speeds. In 1926, the New York Central built its last K-5b Pacific and put plans into motion to develop a larger engine with increased starting tractive effort and greater cylinder power at high speeds with better weight distribution and load balancing. The resulting J1 Hudson's design and striking appearance was influenced greatly by Lima Locomotive Works; but the very first 4-6-4 in the United States was actually delivered by the American Locomotive Company of Schenectady in 1927.

Eventually evolving into the J1e, the NYC warhorse earned its impressive reputation of combining speed and power with its ability to haul 18 cars at 55 MPH. Such a reputation created a demand for production of the locomotive for more than a decade. The years of success of the J1 made the Hudson one of the most time honored steam locomotives ever produced and a virtual trademark of the New York Central Railroad.

MTH Electric Trains is proud to introduce the finest die-cast scale Hudson locomotive ever manufactured for O Gauge operation. Built with all of the craftsmanship and detail that makes MTH Premier Line steam engines the standard of the industry, this J1e will contain more detail and features than any Hudson ever produced for the O Gauge customer. The MTH J1e comes outfitted with a precision Pittman motor and modern flywheel drive train for incredible pulling strength and smooth slow speed operation. She is equipped with our state-of-the-art ProtoSound digital sound and train control system which includes our popular Passenger Station Proto-Effects™ feature. When ordered with a matching set of scale madison cars decorated in NYC Pullman Green livery, you'll own one of the most handsome and famous consists to ever run the rails.

NYC J-1e HUDSON LOCOMOTIVE

The Premier Line New York Central J1e Hudson is the finest hudson ever produced for the O Gauge customer. Thanks to superb computer assisted control over the tool making proc-

ess, we have ensured that this J1e intricately captures much of the detail of the actual prototype. The resulting masterpiece is a scale engine that you can cherish for a lifetime.

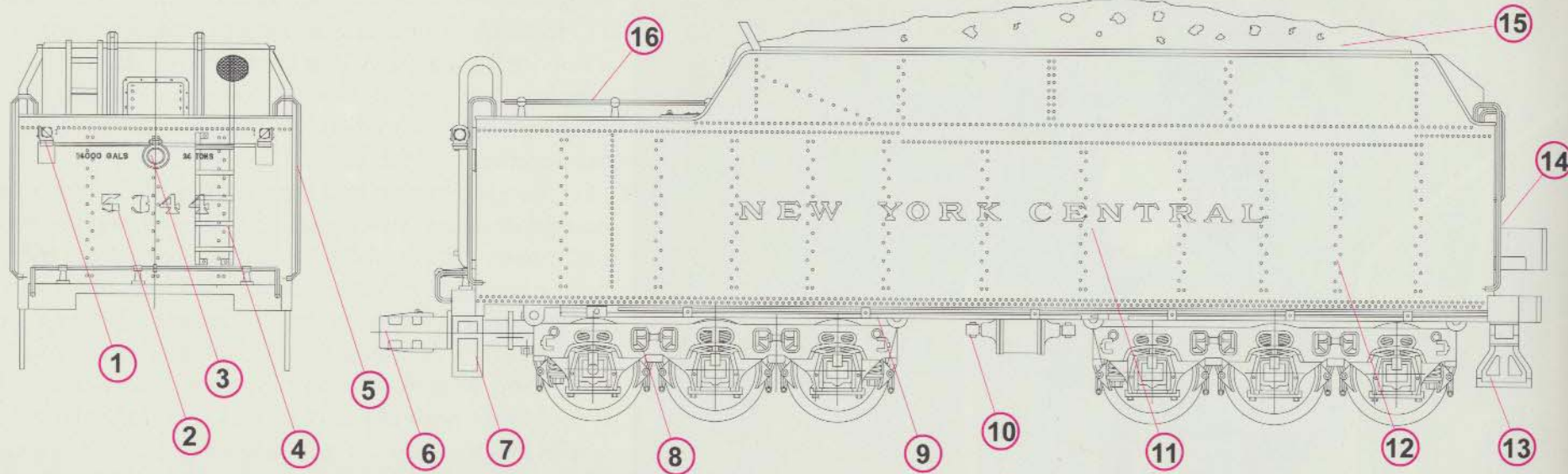

NEW YORK CENTRAL J-1e

TENDER DETAILS

- 1 Operating Marker Lights
- 2 Tender Lettering
- 3 Operating Backup Light
- 4 Tender Ladder
- 5 Metal Handrails
- 6 Operating ProtoCoupler
- 7 Metal Tender Ladder
- 8 Die-Cast Tender Trucks
- 9 Pipes and Pipe Hangers
- 10 Tender Brake Cylinders
- 11 Tender Lettering
- 12 Die-Cast Tender Body
- 13 Metal Engineer's Step
- 14 Tender Tread Plate
- 15 Real Tender Coal Load
- 16 Manhole Covers

LOCOMOTIVE DETAILS

- 1 Boiler Lettering
- 2 Tender Drawbar
- 3 Injector Pipes

- 4 Die-Cast Trailing Truck
- 5 Spoked Trailing Wheels
- 6 Detailed Ashpan
- 7 Booster Exhaust Pipe
- 8 Driver Brake Shoes
- 9 Reversing Mechanism
- 10 Spoked Drive Wheels
- 11 Main Driver Side Rod
- 12 Boiler Air Tanks
- 13 Side Rod
- 14 Piston Drive Rod
- 15 Eccentric Crank Rod
- 16 Main Linkage Frame
- 17 Crosshead Guides
- 18 Pilot Truck Brake Shoes
- 19 Automatic Lubricator
- 20 Steam Chest
- 21 Air Pumps
- 22 Pilot
- 23 Pilot Coupler Lift Bar
- 24 Boiler Steps
- 25 Metal Boiler Handrails

- 26 Builders Plate
- 27 Booster Exhaust Stack
- 28 Operating Smoke Stack
- 29 Super Heater Cover Plate
- 30 Air Pump Steam Pipe
- 31 Sand Dome
- 32 Injector Valve
- 33 Air Brake Pipe
- 34 Steam Dome
- 35 Feed Water Delivery Pipe
- 36 Metal Whistle
- 37 Lower Valve Rod
- 38 Siphon & Safety Valves
- 39 Turret Casing
- 40 Boiler Cab Ventilators
- 41 Engineer Figure
- 42 Detailed Cab Interior
- 43 Operating Firebox Glow
- 44 Operating Marker Lights
- 45 Opening Boiler Front Door
- 46 Operating Boiler Headlight
- 47 Pilot Coupler

In order to fully capture the feel of the New York Central legend, many of the parts are separately cast and then hand assembled to the boiler. In fact, there are over 500 separate actions required to fully assemble the MTH J1e. Throughout this process, however, careful attention is paid to the quality of the components. Any parts not meeting our high standard of quality are immediately rejected.

Because we expect our customers to run these engines, they are tested for complete operating functionality. In order to fully test all of the features of the engine our quality control inspectors must complete over two dozen different operating tests!

While these may seem like extreme and time consuming measures, we feel this level of thoroughness is the best way to guarantee that MTH produces not only the most attractive, but the finest running engines ever made for the O Gauge customer.

NO OTHER HUDSON CAN COMPARE

NYC J-1e HUDSON LOCOMOTIVE

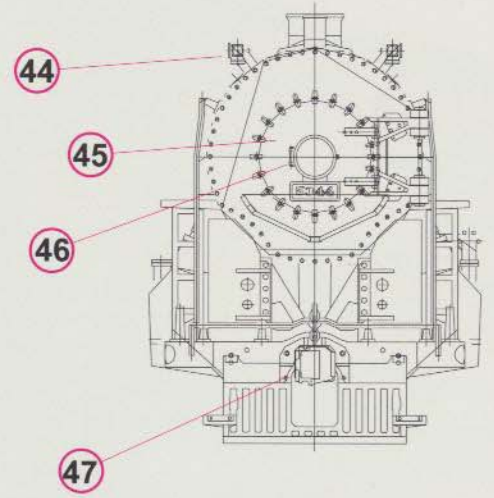
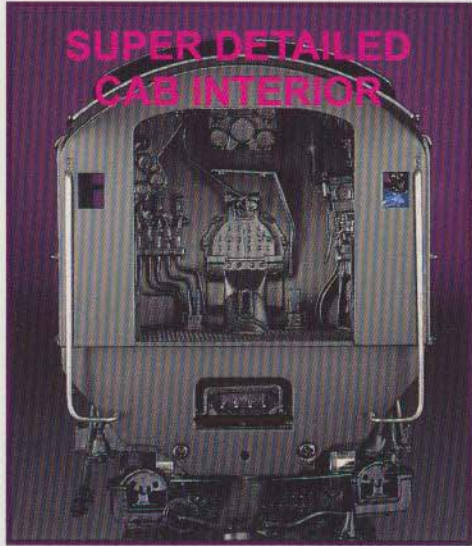
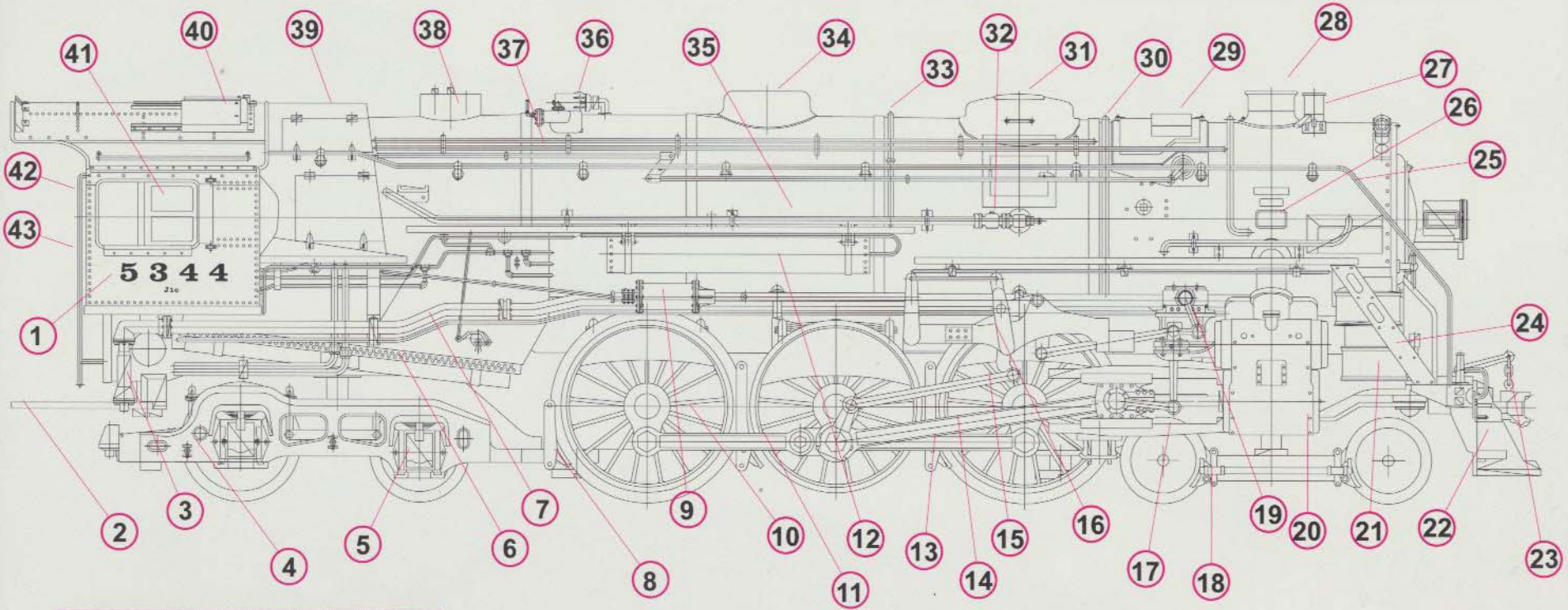

RAIL KINGTM
By MTH Electric Trains

Quality In The Tradition You Remember







When You Equip Your Engine With ProtoSound A LAYOUT COMES ALIVE

Now you can order your most RailKing engines with the exciting MTH ProtoSound system, a state-of-the-art digital sound and train control system that requires no additional equipment or wiring to your layout. You simply hook up any compatible transformer and begin experiencing the digital world of model railroading.

When ordered with ProtoSounds, your RailKing or Premier Line locomotive contains high quality digital sounds you just have to hear to believe. If you

own a steam engine, you'll be treated to the sounds of synchronized chuffing, authentic whistle and bell sounds, air compressor pump and let-off sounds as well as other randomly played sounds too numerous to mention! Diesel engines outfitted with ProtoSounds feature an 8-level diesel motor sound, authentic diesel horn and bell sounds, air compressor pump and let-off sounds as well as our exclusive "Cab Chatter" sounds - digitally captured radio transmissions of actual train engineers and dispatchers.

But that's not all. Each ProtoSound equipped engine also features the sound of squeaking brakes. Whenever the brake feature is activated (a simple process with any compatible transformer), you'll hear 'em pierce your ears as you throttle down your transformer. Imagine how realistic your layout operations will become when you slow down your engine before entering a curve or a station and hear the squeaking sounds of the brakes!

There's even more! When activated you can hear additional sound effects for passenger and freight engines. Run a RailKing SD60 or Premier Line GP-20 ProtoSound equipped engine into a freight yard. After coming to a stop you'll hear the sounds of your freight consists' cargo being unloaded. The sound effects are complete with sliding box door sounds, thumping

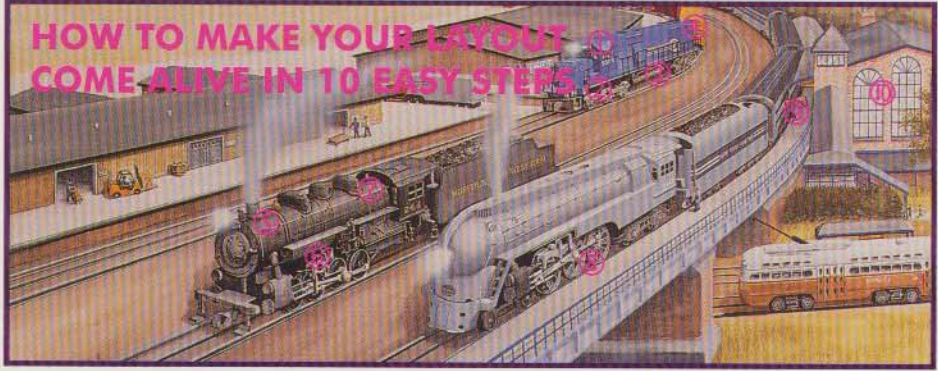

- ① Add A Diesel Horn
- ② Add A Diesel Bell
- ③ Add Diesel Engine Sound
- ④ Add Freight Yard Sounds
- ⑤ Add A Steam Bell
- ⑥ Add Steam Chuffing
- ⑦ Add A Steam Whistle
- ⑧ Add Squeaking Brakes
- ⑨ Add Passenger Sounds
- ⑩ Add Station Sounds

OR, JUST BUY YOUR NEXT ENGINE WITH PROTOSOUND!

pallet sounds, forklift truck sounds, even the warning bell of the forklift. It's simply amazing!

Pull your RailKing Dreyfuss or Premier Line J1e Hudson into a passenger station and get ready to hear the sounds of your passengers disembarking! You'll know its about to happen when the station's public address speaker calls out the arival of your train just after it arrives at the platform. From there you'll hear your conductor warning the passengers to watch their step and where to go for their luggage. When you're ready to leave the station, you'll hear the public address speaker announce that your engine is ready to depart. As your passengers begin boarding, they are greeted by your conductor. Just before you're ready to leave, your passengers will be called once more by the conductor's famous "All Aboard" cry. That's quickly followed by the sound of the car doors closing and the engine's bell tolling. Then, automatically, your engine rolls away from the platform. It's easy, fun and requires no additional equipment!

PROTOSOUND FEATURES

DIESEL ENGINES

- Variably Controlled 8 Step Diesel Sound
- Authentic Diesel Horn
- Authentic Diesel Bell
- Air Compressor Pump & Letoff Sounds
- Squeaking Brakes
- Randomly Activated Cab Chatter Sequences
- Freight Yard Sound Effects
- Remote Controlled Engine Volume Adjustment
- Remote Controlled Engine Lockout Setting
- Operates With Any Compatible AC Transformer
- Self-Recharging Battery Backup With Auto Shut-off
- Directionally Controlled Constant Voltage Headlights*
- **Remote Controlled Metal Proto-Couplers***

*Factory equipped on Premier Line models

STEAM ENGINES

- Synchronized Steam Chuffing Sound
- Authentic Steam Whistle
- Authentic Steam Bell
- Air Compressor Pump & Letoff Sounds
- Squeaking Brakes
- Randomly Activated Steam Neutral Sounds
- Passenger Station Proto-Effects™
- Remote Controlled Engine Volume Adjustment
- Remote Controlled Engine Lockout Setting
- Operates With Any Compatible AC Transformer
- Self-Recharging Battery Backup With Auto Shut-off
- **Remote Controlled Metal Proto-Couplers***

*Factory equipped on Premier Line models

RAIL KING
By MTH Electric Trains

PCC ELECTRIC STREET CAR

The great rise in popularity of automobiles created a desperate effort in the late 1920's to save the dying street car railway industry. It became essential to design a modern street car with a high level of comfort and public acceptance capable of maintaining its place in automobile traffic. The resulting effort gave us the PCC car.

MTH is proud to introduce a true-to-scale RailKing model of the famous PCC car decorated in Philadelphia's SEPTA gold and white livery. Because our model is built in true 1/4 inch dimensions it will be at home in both scale and O-27 pikes and Christmas Gardens. Loaded with RailKing features, this smooth and quiet running scale people mover will please even the most discriminating railroad enthusiast.



Philadelphia PCC Electric Street Car
Item No. 2007

PCC ELECTRIC STREET CAR

- Directionally Controlled Headlights
- Die-Cast 4-Wheel Trucks
- True 1/4 Scale Proportions From Actual Prototype
- Colorful Philadelphia Paint Scheme
- Metal Handrails & Operating Pantograph
- Operates On O-27 Track
- DCRU™ Electronic Reverse Unit
- Operates With Any AC Transformer
- Accepts Plug-In ProtoSound™ Digital Sound Control Modules
- Precision Flywheel Equipped Motor
- Lighted Cab Interior
- Operating Marker Lights
- Measures Approximately 11^{5/8}" x 2^{1/2}" x 3^{1/2}"

PCC ELECTRIC STREET CAR



Traditionally Sized For O-27 Operation

NYC DREYFUSS HUDSON

Affordable Classic Streamlined Looks

Announcing the second RailKing streamlined steamer, the New York Central's famous Dreyfuss Hudson. It just

may be one of America's most beautiful streamliners to ever run the rails!

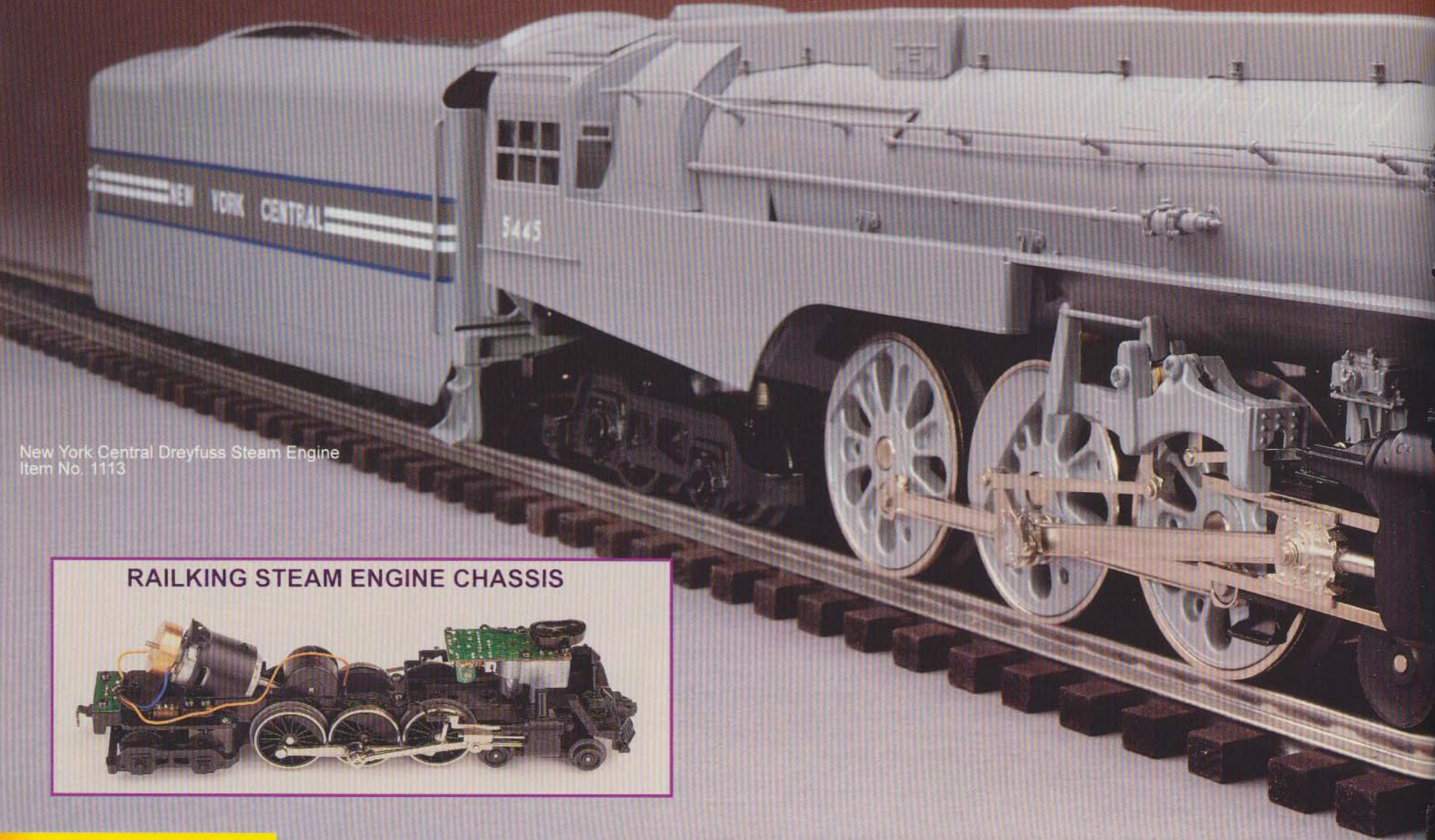

New York Central Dreyfuss Steam Engine
Item No. 1113

RAILKING STEAM ENGINE CHASSIS



Built with RailKing value and toughness, this famous steamer, like all of our RailKing steam engines, features an all die-cast boiler and tender body. The engine is mounted atop our revolutionary die-cast chassis and features a smooth running, flywheel coasting drive train for incredible pulling power.

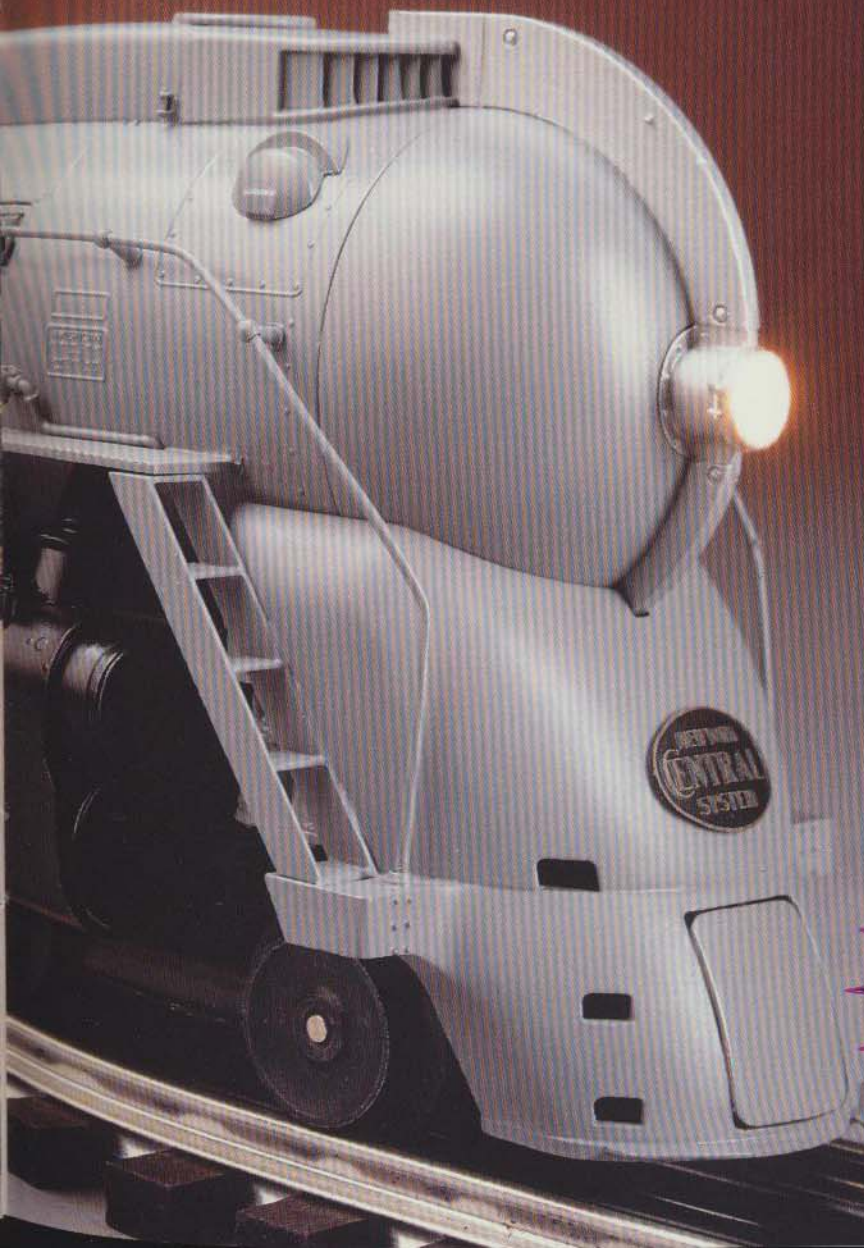

Painted in authentic New York Central colors, the beautiful Dreyfuss will likely be one of the most attractive engines on your layout. Better yet, with its value-packed features, it will be one of the most fun engines on your layout. You'll enjoy the standard equipped electronic whistle and marvel at the awesome output from the Proto-Smoke smoke system. But if you really want a railroading blast, opt for the ProtoSound equipped version. The state-of-the-art digital sounds include realistic chuffing sounds, a digital whistle and bell, air compressor pump sounds, squeaking brakes and the most remarkable station announcement sounds you've ever heard. It's guaranteed to amaze even the most skeptical railroading fan!

NYC DREYFUSS STEAMER

- Operating Headlight
- Die-Cast Boiler and Tender
- Operates On O-27 Track
- Metal Handrails & Decorative Whistle
- Equipped With Operating Electronic Whistle
- Operating Proto-Smoke System
- Compatible With Most AC Transformers
- Optionally Equipped With ProtoSound™ Digital Sound Control**
- Precision Flywheel Equipped Motor
- DCRU™ Electronic Reverse Unit
- Detailed Cab Interior
- Die-Cast Tender Truck Sides
- Operating Metal Couplers
- Measures Approximately 21¹/₄" x 2¹/₂" x 3¹/₂"

Optionally
Equipped With

PROTO - SOUND™

DESIGNED BY OSIN

See Page 30 For Details

RAIL KING
By MTH Electric Trains

Traditionally Sized For O-27 Operation

SD-60 DIESEL LOCOMOTIVE

Introducing modern EMD power for O-27!

With the release of the all-new RailKing SD60 diesel, your O-27 pike can now enjoy many of the same operating features our Premier Line engines have employed over the years. Decorated in either the colorful Chicago Northwestern or Conrail paint scheme, each RailKing SD60

contains two precision flywheel-coasting motors for incredible pulling strength. There simply is no other O-27 engine that pulls as well as a RailKing diesel.

Each RailKing SD60, like all of our diesels, contains a stamped metal floor, die-cast trucks, pilots and trucksides - you won't find any plastic here! The trucks are equipped

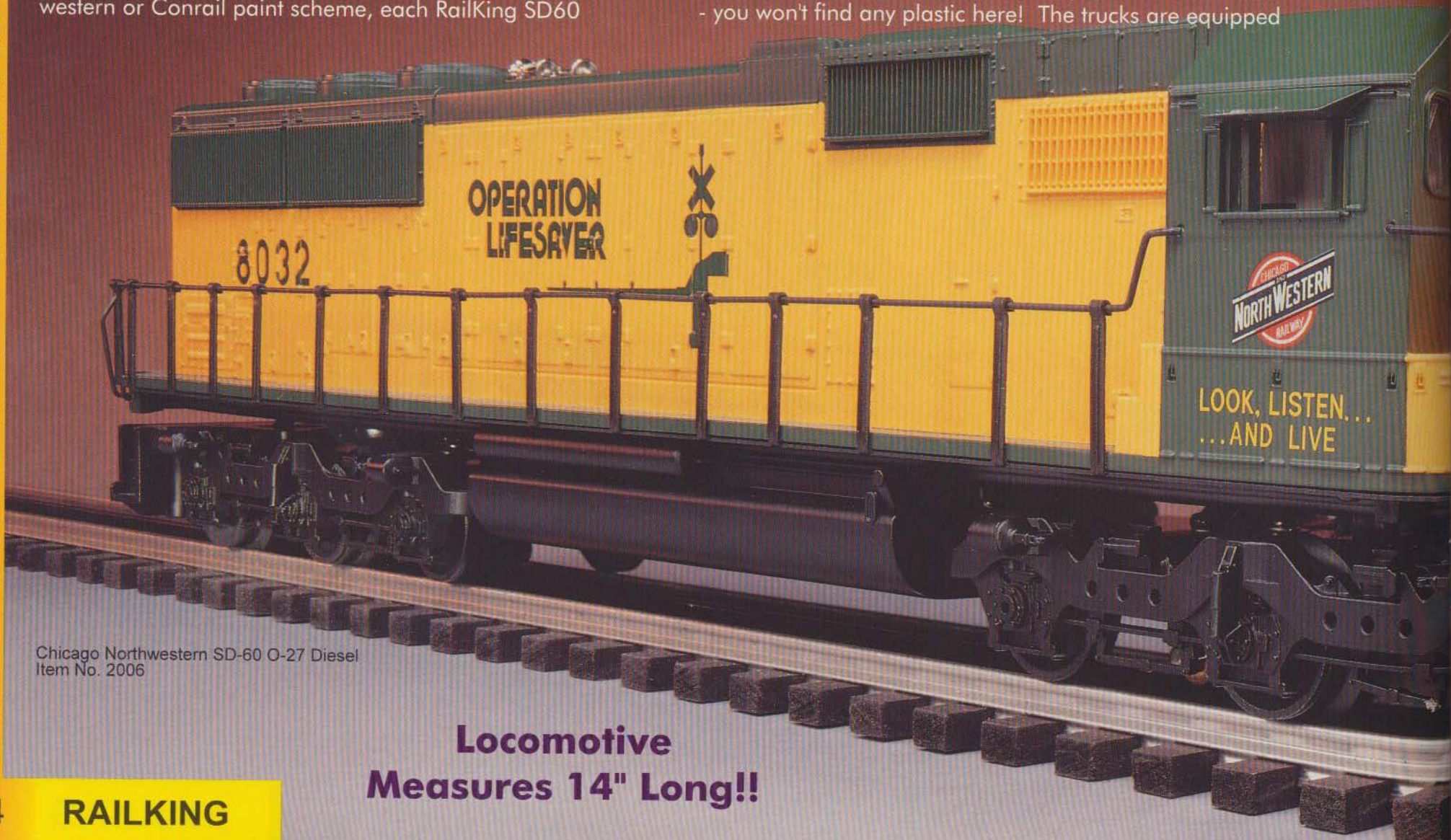

Chicago Northwestern SD-60 O-27 Diesel
Item No. 2006

**Locomotive
Measures 14" Long!!**

with die-cast operating couplers and the body is adorned with decorative metal handrails and horn for years of handling no matter how experienced the engineer!

Each RailKing SD60 comes equipped with our standard electronic horn and electronic reverse unit. But if you really want railroading realism, order your SD60 with our state-of-the-art ProtoSound digital sound system which features diesel engine sounds, digitally captured horn and bell sounds, freight yard loading sounds and authentic two-way radio cab chatter clips! It's so real sounding, you'll swear there is a real railroad running through the house!



SD60 DIESEL

- Operating Headlights
- Intricately Detailed Durable ABS Body
- Stamped Metal Floor
- Available In 2 Popular Roadnames
- Operates On O-27 Track
- Metal Handrails & Decorative Horn
- Equipped With Operating Electronic Horn
- Compatible With Most AC Transformers
- **Optionally Equipped With ProtoSound™ Digital Sound Control**
- 2 Precision Flywheel Equipped Motors
- DCRU™ Electronic Reverse Unit
- All-Metal Wheels & Gears
- Die-Cast Tender Trucks
- Operating Metal Couplers
- Measures Approximately 14' x 2 1/2" x 3 1/2"

Conrail SD-60 O-27 Diesel - Item No. 2005



Optionally
Equipped With

PROTO - SOUND
TM

DESIGNED BY **OSTN**

See Page 30 For Details

RAIL KING
By MTH Electric Trains

A True-To-Scale 0-8-0 Comes To RailKing

0-8-0 SCALE SWITCHER

The process of making up loads into trains - known as switching - is one of the least glamorous, although most expensive, of all railroad operations. Smaller, agile yard switchers were introduced as the most cost effective means of getting this job done.

Chicago Northwestern 0-8-0 Switcher
Item No. 1112

ALSO AVAILABLE IN

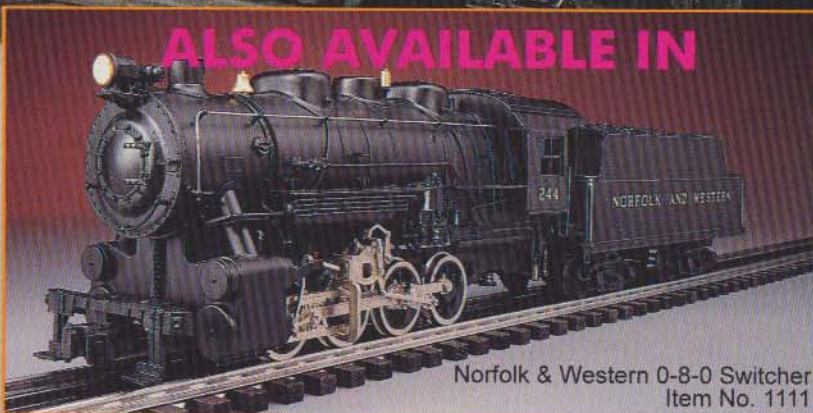

Norfolk & Western 0-8-0 Switcher
Item No. 1111

**Operates On
O-27 Curves!!**

**Loco & Tender
Measure Over
18" Long!!**

**Optionally
Equipped With**

PROTO - SOUND™

DESIGNED BY **OSLN**

See Page 30 For Details

Of all the switchers developed, perhaps none was more effective than the famous 0-8-0. These gusty workhorses, developed from the U.S.R.A. 0-8-0 plans, were vital to the heavy transfer and coal hauling traffic on many of America's railroads. They proved so reliable that many remained in service well into the 1950's.

As the first true-to-scale steamer ever offered in our RailKing line, the RailKing 0-8-0 will prove to be a reliable workhorse on any O or O-27 pike. Constructed with our famous die-cast chassis and flywheel coasting drive train, the RailKing 0-8-0 will perform with smoothness and strength on even the tightest O-27 turns and is sure to satisfy even the most hardened O Scale operator.

Outfitted with the incredible Proto-Smoke puffing smoke system that is unrivaled in the market, the RailKing 0-8-0 comes equipped with an electronic whistle or can be outfitted with our state-of-the-art ProtoSound system. Regardless of which configuration or which of the two roadnames you choose, the engine will be a favorite on anyone's pike.

U.S.R.A 0-8-0 STEAMER

- Operating Headlight
- Die-Cast Boiler and Tender
- True 1/4 Inch Scale Proportions
- Available In 2 Popular Roadnames
- Operates On O-27 Track
- Metal Handrails & Decorative Whistle
- Equipped With Operating Electronic Whistle
- Operating Proto-Smoke System
- Compatible With Most AC Transformers
- Optionally Equipped With ProtoSound™ Digital Sound Control*
- Precision Flywheel Equipped Motor
- DCRU™ Electronic Reverse Unit
- Detailed Cab Interior
- Die-Cast Tender Trucks
- Operating Metal Couplers
- Set Measures Approximately 18^{3/4}" x 2^{1/2}" x 3^{5/8}"

RAIL KING
By MTH Electric Trains

O-27 PASSENGER CARS



RailKing passenger cars are designed for years of operating fun, with sturdy metal floors, die-cast trucks and couplers, and tough ABS plastic bodies. They include an illuminated cab interior and end-of-car diaphragms for even more realism! In addition, all RailKing passenger cars feature smooth rolling needle point axles for less drag and easy pulling. Line up an Amtrak or Santa Fe set behind your RailKing Dash-8 or GG-1 for terrific operating fun!

STREAMLINED O-27 PASSENGER CARS

- Durable ABS Intricately Detailed Bodies
- Die-Cast 4 Wheel Trucks
- **Operating Die-Cast Metal Couplers**
- Available In Two Popular Roadnames
- Operates On O-27 Track
- **End Of Car Diaphragms**

- Fast Angle Wheel Sets
- Needle-Point Axles
- **Detailed Seat Interiors**
- Stamped Metal Floors
- Overhead Interior Lighting
- Cars Measure 12^{1/2} x 2^{1/2} x 3^{3/4}.



Santa Fe O-27 Passenger Car Set



Includes Overhead Lighting & Seat Interiors!!

Santa Fe O-27 Baggage Car - Item No. 6010



Santa Fe O-27 Passenger Coach - Item No. 6011



Santa Fe O-27 Vista Dome Car - Item No. 6012



Santa Fe O-27 Observation Car - Item No. 6013



RAIL KING
By MTH Electric Trains

SEMI-SCALE FREIGHT CARS

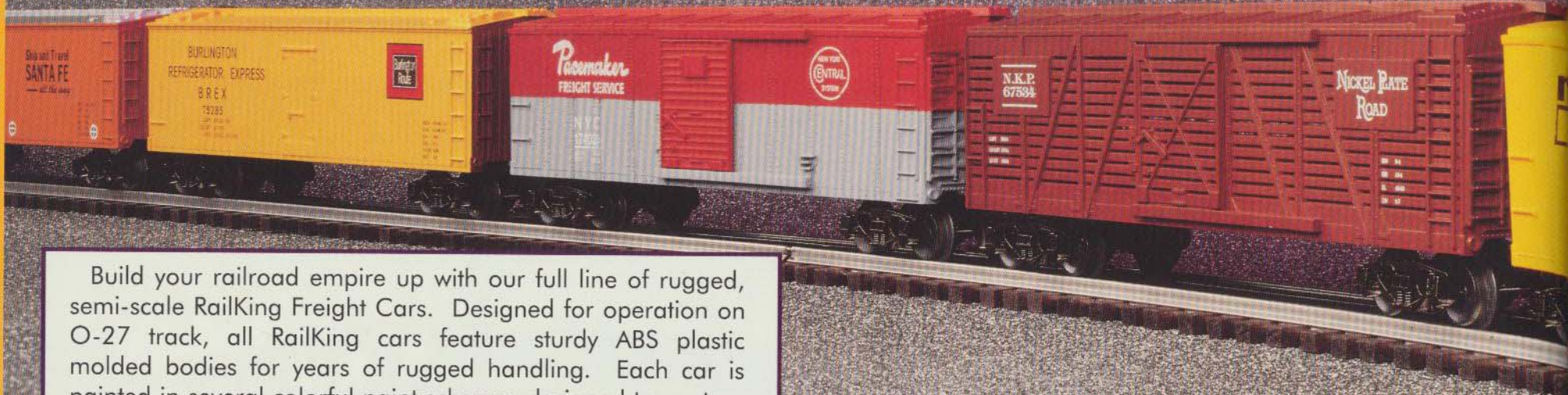

Build your railroad empire up with our full line of rugged, semi-scale RailKing Freight Cars. Designed for operation on O-27 track, all RailKing cars feature sturdy ABS plastic molded bodies for years of rugged handling. Each car is painted in several colorful paint schemes designed to capture the real feel of today's and yesterday's railroads.

Santa Fe Tankcar - Item No. 7306



Chicago Northwestern Tankcar - Item No. 7307



Conrail Tankcar - Item No. 7305



1996 CHRISTMAS BOXCAR!!

1996 MTH Christmas Boxcar - Item No. 7410

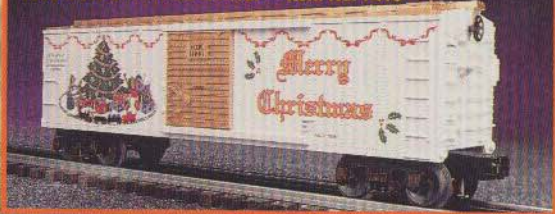

SEMI-SCALE FREIGHT CARS

- Durable ABS Intricately Detailed Bodies
- Die-Cast 4 Wheel Trucks
- Operating Die-Cast Metal Couplers**
- Colorful Paint Schemes
- Operates On O-27 Track
- Decorative Brake Wheels

- Fast Angle Wheel Sets
- Needle-Point Axles
- Sliding Box Car Doors
- Stamped Metal Floors On Most Cars
- Sliding Stock Car Doors
- Measures Approximately 10^{3/4} x 2^{1/2} x 3^{3/4}.

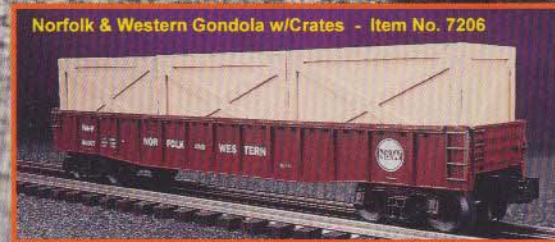
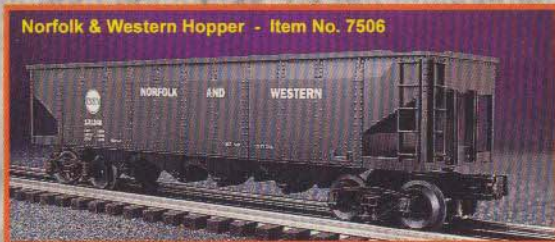
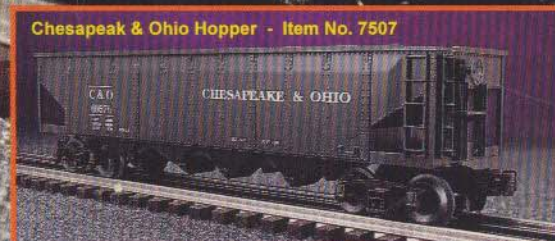
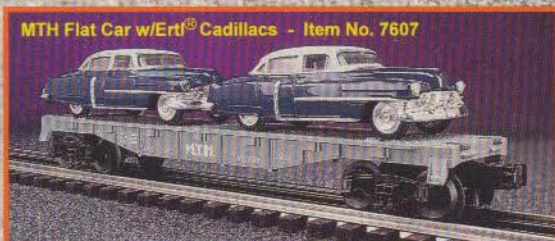
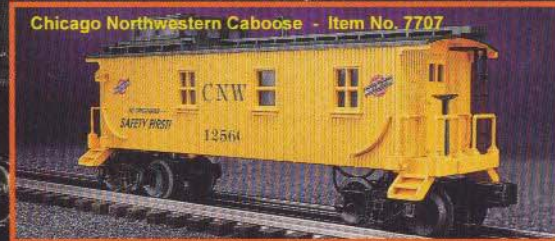
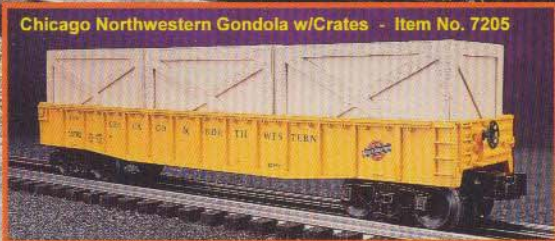
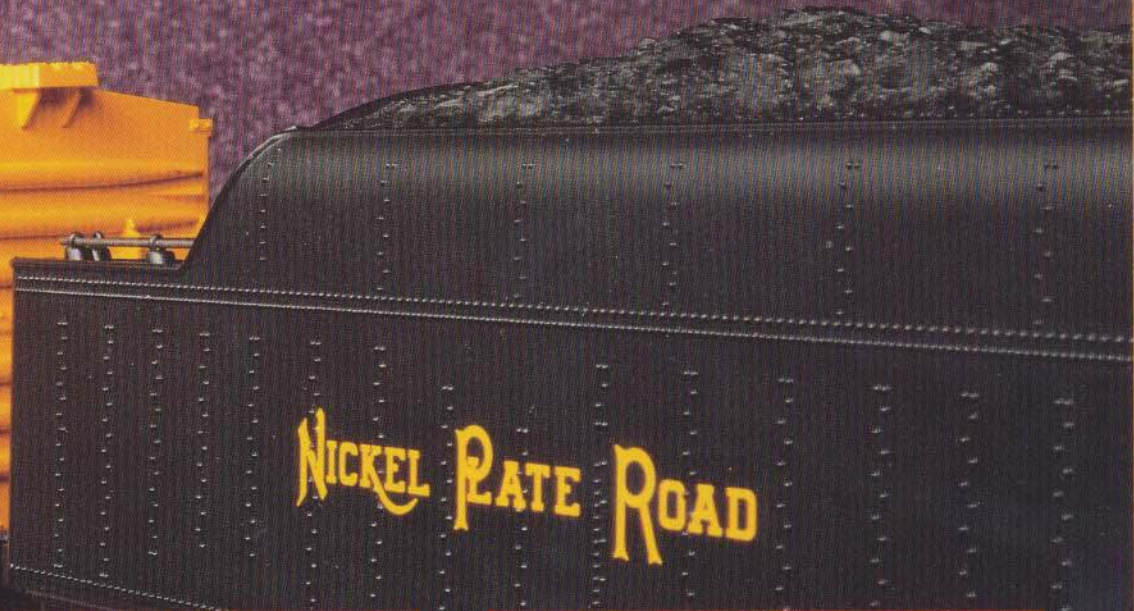

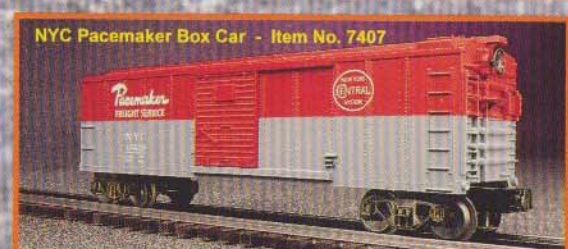
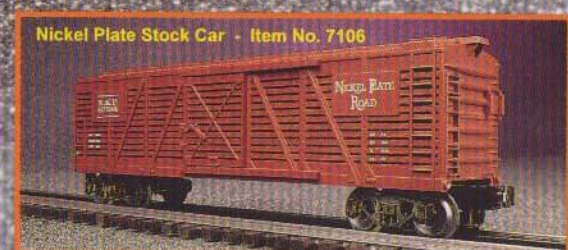
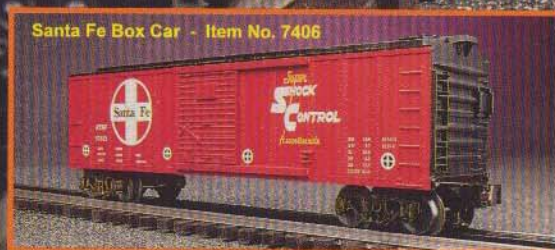
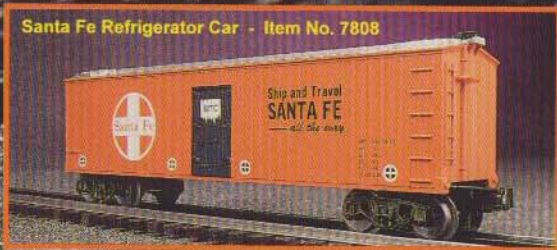



Nickel Plate Road Hopper Car - Item No. 7505



Erie Caboose - Item No. 7706



Nickel Plate Road Flatcar - Item No. 7605



Burlington Refrigerator Car - Item No. 7806



Railway Express Agency Refrigerator Car - Item No. 7810



RailBox Box Car - Item No. 7409



Pennsylvania Merchandise Box Car - Item No. 7408



Union Pacific Stock Car - Item No. 7107



Santa Fe Stock Car - Item No. 7406



Union Pacific Refrigerator Car - Item No. 7807



Pennsylvania Stock Car - Item No. 7105

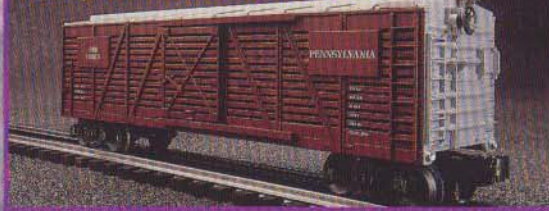

Union Pacific Box Car - Item No. 7405



RAIL KINGTM
By MTH Electric Trains

TRADITIONAL BOXED SETS

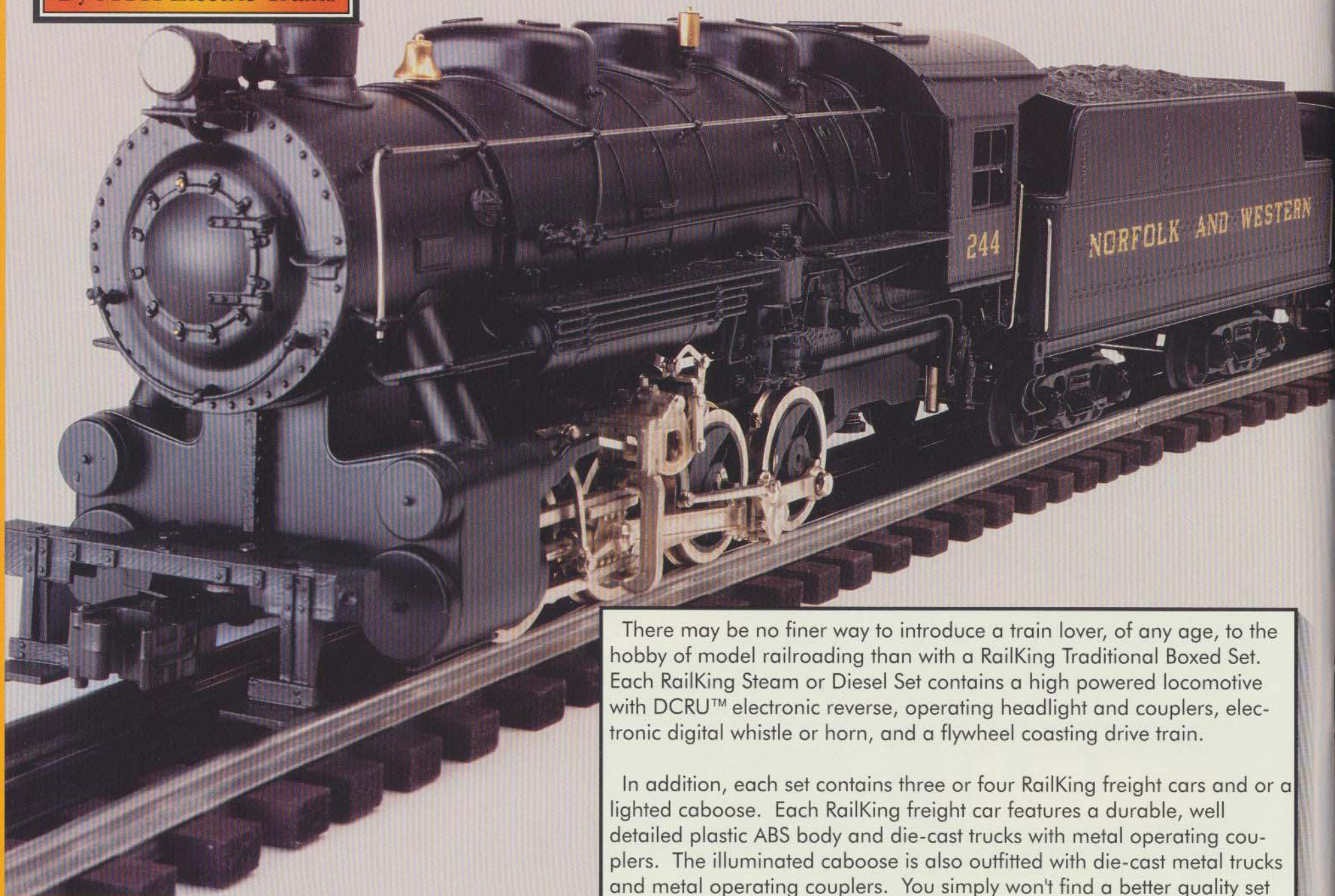

There may be no finer way to introduce a train lover, of any age, to the hobby of model railroading than with a RailKing Traditional Boxed Set. Each RailKing Steam or Diesel Set contains a high powered locomotive with DCRUTM electronic reverse, operating headlight and couplers, electronic digital whistle or horn, and a flywheel coasting drive train.

In addition, each set contains three or four RailKing freight cars and or a lighted caboose. Each RailKing freight car features a durable, well detailed plastic ABS body and die-cast trucks with metal operating couplers. The illuminated caboose is also outfitted with die-cast metal trucks and metal operating couplers. You simply won't find a better quality set for traditional train operations.



**LOOK FOR
THE RAILKING
COLLECTOR BOX
AT YOUR LOCAL DEALER**



CHOOSE FROM 4 EXCITING SETS

CNW SD60 Freight Set - Item No. 029

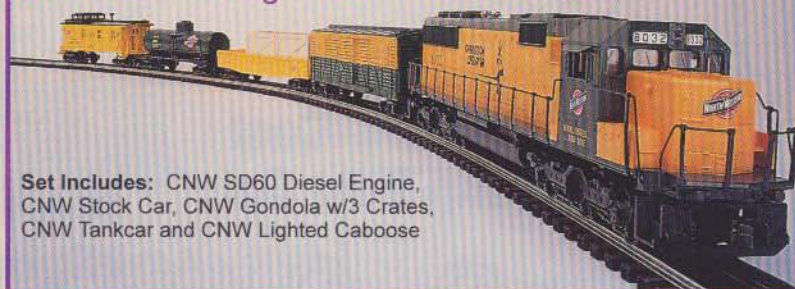

Set Includes: CNW SD60 Diesel Engine, CNW Stock Car, CNW Gondola w/3 Crates, CNW Tankcar and CNW Lighted Caboose

Conrail SD60 Freight Set - Item No. 028

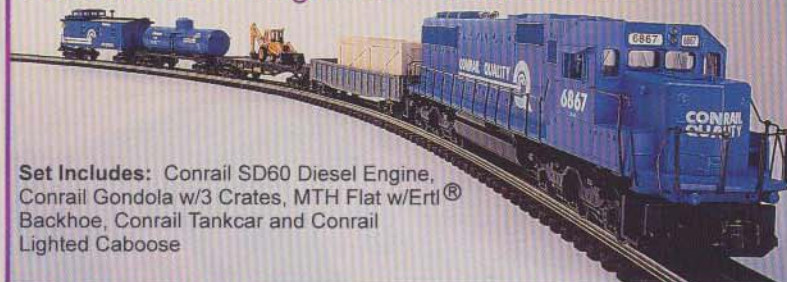

Set Includes: Conrail SD60 Diesel Engine, Conrail Gondola w/3 Crates, MTH Flat w/Ertl® Backhoe, Conrail Tankcar and Conrail Lighted Caboose

CNW 0-8-0 Freight Set - Item No. 027



Set Includes: CNW 0-8-0 Switcher Steam Engine, CNW Stock Car, CNW Gondola w/3 Crates, CNW Tankcar and CNW Lighted Caboose

RAILKING FREIGHT CARS ALSO AVAILABLE SEPARATELY

Locomotive & Cars Each Boxed Separately Within Collector Box

* Track & Transformer Not Included

MTH LAYOUT ACCESSORIES

Light Up Your Railroad In Classic Form

Choose from four classic street lamp models, each beautifully capturing the feel of yesteryear's railroading memories. These die-cast metal lamps are attractively decorated in a glossy baked enamel finish in a variety of colors. Their heavy cast base contains pre-wired power leads making them a cinch to wire up to standard AC track current.



#59 Die-Cast Lamp Post Set

#59 Lamp Set
Contains 2 Lamps
Each Measures
8¹/₂ Inches Tall

Available In: Maroon - Item No. 1030 or Green - Item No. 1031



#57 Die-Cast Street Lamp Set

#57 Lamp Set
Contains 2 Lamps
Each Measures
7³/₈ Inches Tall

Available In: Yellow - Item No. 1028
or Orange - Item No. 1029



#56 Die-Cast Street Lamp Set

#56 Lamp Set
Contains 2 Lamps
Each Measures
8 Inches Tall

Available In: Green - Item No. 1026 or
Maroon - Item No. 1027



No. 64 'O' Die-Cast Highway Lamp Post



#64 Lamp Set
Contains 2 Lamps
Each Measures
6³/₄ Inches Tall

Available In:
Dark Green - Item No. 1032
or Maroon - Item No. 1033

#4449 O Gauge Lighted Lockon

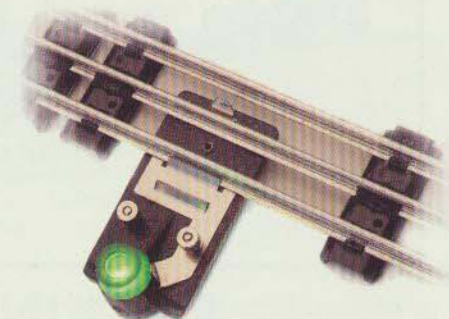

Available In: O Gauge - Item No. 1021



RAILTOWN™ BUILDINGS

RAILTOWN BUILDINGS

Equipped With Interior Illumination

An Exciting All-New Series Of O Gauge Buildings

Add a splash of life to your layout with these quality-built RailTown Buildings. Made from sturdy ABS plastic and brightly decorated, RailTown buildings are the perfect size for your RailKing locomotives and cars. Each building contains interior illumination and comes completely assembled. Choose from three colorful, pre-assembled models or buy all three and start building your own RailTown.



#6 Farm House - Item No. 9001
Measuring Approximately 8^{1/4} x 8^{1/16} x 7 Inches Tall



#5 Country Church - Item No. 9002
Measuring Approximately 6^{1/2} x 4^{1/4} x 11^{3/4} Inches Tall

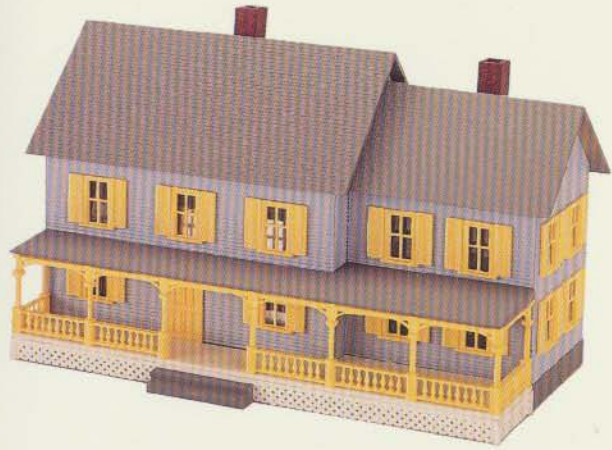

#4 Country House - Item No. 9003
Measuring Approximately 11 x 4^{1/4} x 11^{3/4} Inches Tall

All Buildings Come Preassembled And Prepainted

STAY ON SCHEDULE!

#1210 RailKing Clock
Battery Powered Clock
Measures 10 Inches Across

MTH ELECTRIC TRAINS TURNING YOUR MEMORIES INTO FULL-COLOR REALITY

Santa Fe Warbonnet F-3
Coming In 1997

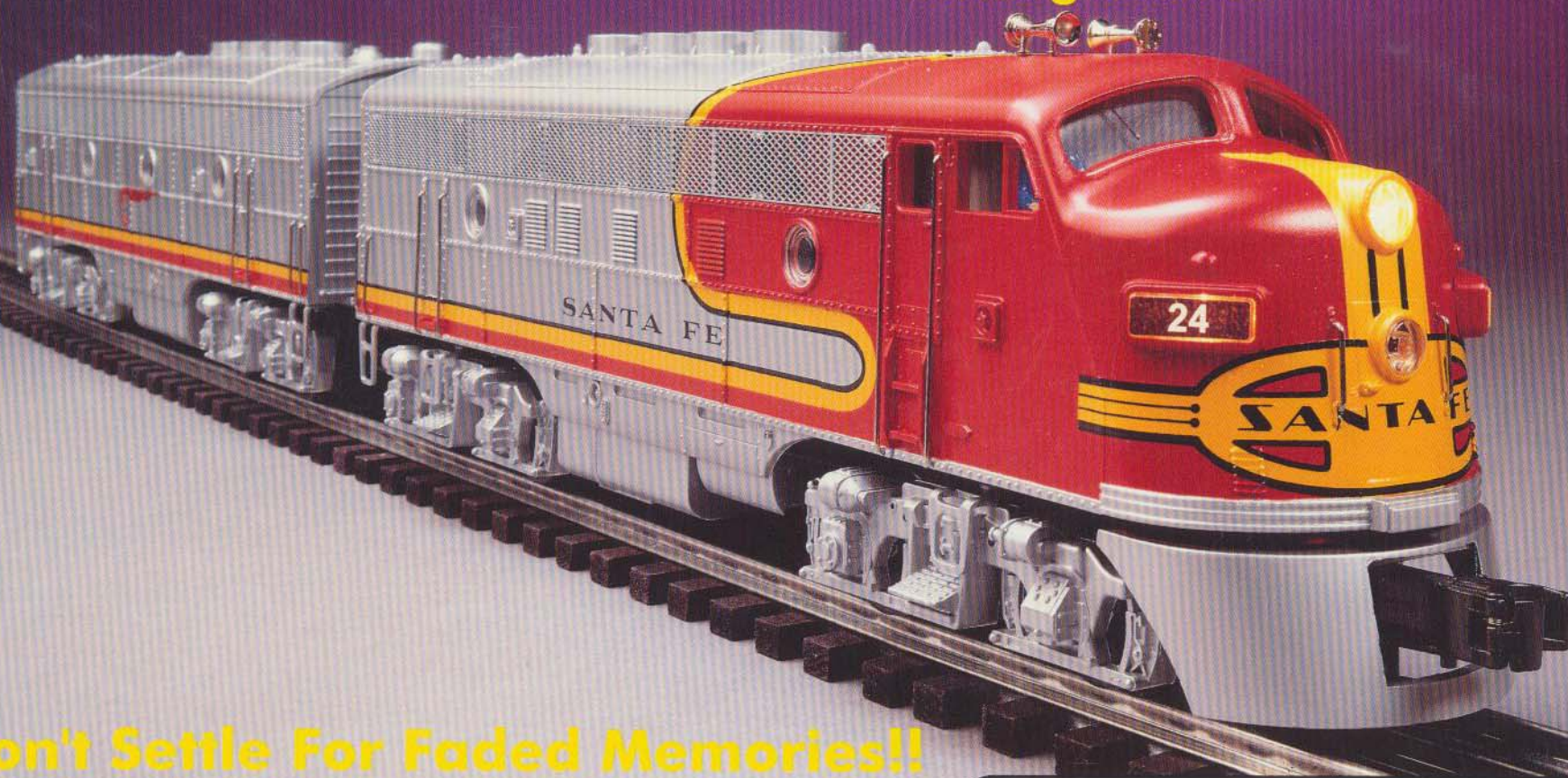

Don't Settle For Faded Memories!!

All products depicted in this catalog are not production models. In some cases, the models pictured may be HO, O Scale or some other scale product. All item's graphics, features and content are subject to change after publication. All product features may be verified on their retail packages.

© 1996, MTH Electric Trains, Columbia, MD. Trademarks: ProtoSounds, RailTown, RailKing, The MTH Numbering System and all others indicated throughout this catalog. DCRU and QSI are registered trademarks of QS Industries. Lionel Classics and Lionel are registered trademark of Lionel L.L.C.